



METROPARKS TOLEDO

Vision

Metroparks Toledo will be, in its culture and community engagements, the beacon for conservation of natural resources; diversity, equity, and inclusion; and the activation and promotion of spaces that enhance physical and mental health. The communal pursuit of these aspirations will elevate our region and transform its identity.

Mission

The mission of Metroparks of the Toledo Area is to conserve the region's natural resources by creating, developing, improving, protecting, and promoting clean, safe, and natural parks and open spaces for the benefit, enjoyment, education, and general welfare of the public.

MEETING AGENDA

METROPOLITAN PARK DISTRICT OF THE TOLEDO AREA
WEDNESDAY, JANUARY 18, 2023, 8:30 A.M.
GLASS CITY PAVILION – GLASS CITY METROPARK

ROLL CALL

Executive Director: David D. Zenk

Commissioners: President Scott Savage, Vice President Lera Doneghy, Vice President Fritz Byers, Molly Luetke, Kevin Dalton

Others present and appearing before the Board: Shawn Nelson

BOARD MEETING

1. 8:30 a.m. to 8:35 a.m. **NON-RESOLUTION BOARD ITEMS**

A. Pledge of Allegiance

2. 8:35 a.m. to 10:00 a.m. **CONSENT AGENDA ITEMS**

The president will propose a blanket motion to approve all items. Before the motion, all those present will have the opportunity to remove any item from the consent agenda and discuss separately.

A. Board Changes or Additions to the Agenda and Reading and Disposition of Minutes of the Regular Board Meeting held on December 14, 2022.

3. **CONSIDERATION OF REPORTS FROM DIRECTOR AND EMPLOYEES OF THE DISTRICT FOR REVIEW**

A. Earned Revenue Plan – Mike Keedy, Director of Enterprise Development

B. Aquatic Management Action Projects in the Maumee Area of Concern – Zuri Carter, Deputy Chief of Natural Resources and Tim Schetter, Chief Natural Resources Officer

C. Treasurer's Report – Matt Cleland, Chief Financial Officer/Treasurer

4. BOARD APPROVAL OF CONTRACTS, DEEDS, AGREEMENTS, ETC.

A. Contracts, Deeds, Agreements, Etc.

Resolution No. 01-23	Approval of Supplement and Amendment to the 2022 Certificate of Estimated Resources and Appropriations Measure	Pg. # 27
Resolution No. 02-23	Amendment to Board Resolution No. 96-22, "Authorization of Amendment 96-22 for the Purchase of General Liability, Etc. Insurance Coverage from Hylant Administrative Services"	Pg. # 29
Resolution No. 03-23	Ratification of Schedule of Payables	Pg. # 30
Resolution No. 04-23	Entity Beneficiary Resolution	Pg. # 32
Resolution No. 05-23	Authorization to Request Funding Through the Ohio Environmental Protection Agency	Pg. # 34
Resolution No. 06-23	Approval of First Amendment to Project Partner Agreement with The Nature Conservancy	Pg. # 41
Resolution No. 07-23	Contract Approval, Blue Creek/Neis Ditch Stream Restoration	Pg. # 45
Resolution No. 08-23	Contract Approval, Audubon Islands State Nature Preserve Restoration	Pg. # 48
Resolution No. 09-23	Contract Approval, Pearson Metropark Tennis Court Improvements & Pickleball Conversion	Pg. # 52

5. BOARD INITIATED TOPICS AND DISCUSSION

Regular Board Meeting – December 14, 2022

Resolution Summary

Resolution	Description	Byers	Dalton	Doneghy	Luetke	Savage	
RES 88-22	Approval of Return of Advances from Funds 256, 257 and 258 to General Fund		Motioned	2 nd			Approved
RES 89-22	Approval of Supplement and Amendment to the 2022 Certificate of Estimated Resources and Appropriations Measure			Motioned	2 nd		Approved
RES 90-22	Approval of General Fund Advance	2 nd			Motioned		Approved
RES 91-22	Approval of Final Amendment and Supplement of the 2022 Certificate of Estimated Resources and Appropriations Measure	Motioned	2 nd				Approved
RES 92-22	Establish Use and Amount of Blanket Purchase Orders for 2023		Motioned	2 nd			Approved
RES 93-22	Authorization to Engage the Law Firm Marshall & Melhorn, LLC for Legal Services			Motioned	2 nd		Approved
RES 94-22	Authorization of Issuance of Super Blanket Purchase Order for 2023 Bank Fees	2 nd			Motioned		Approved
RES 95-22	Issuance of Super Blanket and Blanket Purchase Orders for Health Insurance	Motioned	2 nd				Approved
RES 96-22	Authorization of Purchase Order of General Liability, Etc. Insurance Coverage from Hylant Administrative Services			Motioned	2 nd		Approved
RES 97-22	Authorization of Issuance of Super Blanket Purchase Order for Real Estate Taxes	2 nd			Motioned		Approved
RES 98-22	Issuance of Super Blanket Purchase Orders for 2023 Waste Disposal Services	Motioned	2 nd				Approved
RES 99-22	Issuance of Super Blanket Purchase Orders for Utilities		Motioned	2 nd			Approved
RES 100-22	Issuance of Purchase Order for Annual Workers' Compensation Premium	2 nd			Motioned		Approved
RES 101-22	Authorization of Issuance of Super Blanket Purchase Order to Wright Express Fleet Services (Wex Bank)	Motioned		2 nd			Approved
RES 102-22	Authorization of Issuance of Super Blanket Purchase Order to Enterprise Fleet Management			Motioned	2 nd		Approved
RES 103-22	Issuance of Super Blanket Purchase Orders for 2023 Wayfinding Signage			2 nd	Motioned		Approved
RES 104-22	Ratification of Schedule of Payables		Motioned	2 nd			Approved
RES 105-22	Contract Approval, Blue Creek Metropark Electrical Service Renovation			Motioned	2 nd		Approved
RES 106-22	Purchase Contract Increase Approval, Duncan and Grove	Motioned		2 nd			Approved
RES 107-22	Contract Approval, Glass City Riverwalk Professional Construction Administration & Testing Services		Motioned	2 nd			Approved
RES 108-22	Purchase Approval, Zamboni Ice Resurfacers	2 nd			Motioned		Approved



Vision

Metroparks Toledo will be, in its culture and community engagements, the beacon for conservation of natural resources; diversity, equity, and inclusion; and the activation and promotion of spaces that enhance physical and mental health. The communal pursuit of these aspirations will elevate our region and transform its identity.

Mission

The mission of Metroparks of the Toledo Area is to conserve the region's natural resources by creating, developing, improving, protecting, and promoting clean, safe, and natural parks and open spaces for the benefit, enjoyment, education, and general welfare of the public.

BOARD MINUTES

METROPOLITAN PARK DISTRICT OF THE TOLEDO AREA

WEDNESDAY, DECEMBER 14, 2022, 8:30 A.M.

WARD PAVILION – WILDWOOD PRESERVE

Commissioners Present:

Scott Savage, President
Lera Doneghy, Vice President
Fritz Byers, Vice President
Molly Luetke, Officer
Kevin Dalton, Officer

Others present and appearing before the Board: Dave Zenk, Amy Natyshak

Staff Present: Matt Cleland, Ally Effler, Carrie Haddix, Matt Killam, Nate Ramsey, Scott Carpenter, Craig Elton, Brad Navarre, Wendy Garczynski, Bethany Sattler, Zuri Carter, Trish Hausknecht, Felica Clark, Doug Parrish, Brad Hooven, Allen Gallant, Rachael Champion, Jennifer Van Horn, Jon Zvanovec

1. NON-RESOLUTION BOARD ITEMS

President Scott Savage called the meeting to order at 8:35 a.m.

Mr. Scott Savage led the Pledge of Allegiance.

2. CONSENT AGENDA ITEMS

Mr. Fritz Byers made a motion to approve the consent agenda as amended including the disposition of the minutes for the regular Board meeting held on November 15, 2022. This motion was seconded by Ms. Molly Luetke and approved.

3. CONSIDERATION OF REPORTS FROM DIRECTOR AND EMPLOYEES OF THE PARK DISTRICT FOR REVIEW

A. Treasurer's Report - Matt Cleland, Chief Financial Officer/Treasurer

Mr. Matt Cleland reported that any of the budget-to-actual variances have previously been reported on and coming into December, Metroparks Toledo is trending as expected and desired. Salaries and utilities are over

projection for year-to-date, but the budget as a whole is 7% under budget heading into the year's end.

Mr. Byers commented on the significance of expenses being 7% under budget, and that it is remarkable how accurate the projections are year-over-year, providing extreme confidence in the financial forecasting of the organization. Additionally, being below budget indicates a good use of funds, including taxpayer dollars.

Mr. Savage inquired about the abbreviation "CD" on the investment ledger; Mr. Cleland indicated he would follow up and adjust if needed.

4. BOARD APPROVAL OF CONTRACTS, DEEDS, AGREEMENTS, ETC.

- A. Mr. Kevin Dalton offered and moved for adoption of the following resolution, with a second by Mrs. Lera Doneghy:

Resolution No. 88-22 – Approval of Return of Advances from Funds 256, 257 and 258 to General Fund

Mr. Cleland indicated that funds had been advanced from the General Fund to other specific funds to avoid a negative balance. This resolution returns those funds, being reimbursed by grant funds received over the course of the year.

After discussion and upon unanimous vote the resolution was declared duly adopted and recorded in the appendix to these minutes.

- B. Mrs. Doneghy offered and moved for adoption of the following resolution, with a second by Ms. Luetke:

Resolution No. 89-22 – Approval of Supplement and Amendment to the 2022 Certificate of Estimated Resources and Appropriations Measure

After discussion and upon unanimous vote the resolution was declared duly adopted and recorded in the appendix to these minutes.

- C. Ms. Luetke offered and moved for adoption of the following resolution, with a second by Mr. Byers:

Resolution No. 90-22 – Approval of General Fund Advance

Mr. Cleland indicated that this resolution shifts funds from the General Fund to other funds for use over the next year, to be returned following the receipt of grant funds.

After discussion and upon unanimous vote the resolution was declared duly adopted and recorded in the appendix to these minutes.

- D. Mr. Byers offered and moved for adoption of the following resolution, with a second by Mr. Dalton:

Resolution No. 91-22 – Approval of Final Amendment and Supplement of the 2022 Certificate of Estimated Resources and Appropriations Measure

Mr. Cleland indicated that this finalizes all budget adjustments throughout the year to accurately reflect where the funds were utilized.

After discussion and upon unanimous vote the resolution was declared duly adopted and recorded in the appendix to these minutes.

- E. Mr. Dalton offered and moved for adoption of the following resolution, with a second by Mrs. Doneghy:

Resolution No. 92-22 – Establish Use and Amount of Blanket Purchase Orders for 2023

Mr. Cleland indicated that the threshold for blanket purchase orders is currently tied to the state requirement for bidding.

After discussion and upon unanimous vote the resolution was declared duly adopted and recorded in the appendix to these minutes.

- F. Mrs. Doneghy offered and moved for adoption of the following resolution, with a second by Ms. Luetke:

Resolution No. 93-22 – Authorization to Engage the Law Firm Marshall & Melhorn, LLC for Legal Services

Mr. Byers shared his appreciation for the services provided so far by Marshall & Melhorn, LLC.

After discussion and upon unanimous vote the resolution was declared duly adopted and recorded in the appendix to these minutes.

- G. Ms. Luetke offered and moved for adoption of the following resolution, with a second by Mr. Byers:

Resolution No. 94-22 – Authorization of Issuance of Super Blanket Purchase Order for 2023 Bank Fees

After discussion and upon unanimous vote the resolution was declared duly adopted and recorded in the appendix to these minutes.

- H. Mr. Byers offered and moved for adoption of the following resolution, with a second by Mr. Dalton:

Resolution No. 95-22 – Issuance of Super Blanket and Blanket Purchase Orders for Health Insurance

Mr. Dalton inquired into whether Metroparks Toledo employees have a say in changes to the insurance options because of the administration of the program by Lucas County; Mr. Cleland indicated that Metroparks Toledo employees participate in those conversations.

After discussion and upon unanimous vote the resolution was declared duly adopted and recorded in the appendix to these minutes.

- I. Mrs. Doneghy offered and moved for adoption of the following resolution, with a second by Ms. Luetke:

Resolution No. 96-22 – Authorization of Purchase Order of General Liability, Etc. Insurance Coverage from Hylant Administrative Services

Mr. Cleland indicated that the increases in insurance costs are a direct reflection in the increase in what is being insured throughout the park district.

After discussion and upon unanimous vote the resolution was declared duly adopted and recorded in the appendix to these minutes.

- J. Ms. Luetke offered and moved for adoption of the following resolution, with a second by Mr. Byers:

Resolution No. 97-22 – Authorization of Issuance of Super Blanket Purchase Order for Real Estate Taxes

After discussion and upon unanimous vote the resolution was declared duly adopted and recorded in the appendix to these minutes.

- K. Mr. Byers offered and moved for adoption of the following resolution, with a second by Mr. Dalton:

Resolution No. 98-22 – Issuance of Super Blanket Purchase Orders for 2023 Waste Disposal Services

After discussion and upon unanimous vote the resolution was declared duly adopted and recorded in the appendix to these minutes.

- L. Mr. Dalton offered and moved for adoption of the following resolution, with a second by Mrs. Doneghy:

Resolution No. 99-22 – Issuance of Super Blanket Purchase Orders for Utilities

After discussion and upon unanimous vote the resolution was declared duly adopted and recorded in the appendix to these minutes.

- M. Ms. Luetke offered and moved for adoption of the following resolution, with a second by Mr. Byers:

Resolution No. 100-22 – Issuance of Purchase Order for Annual Workers’ Compensation Premium

After discussion and upon unanimous vote the resolution was declared duly adopted and recorded in the appendix to these minutes.

- N. Mr. Byers offered and moved for adoption of the following resolution, with a second by Mrs. Doneghy:

Resolution No. 101-22 – Authorization of Issuance of Super Blanket Purchase Order to Wright Express Fleet Services (Wex Bank)

After discussion and upon unanimous vote the resolution was declared duly adopted and recorded in the appendix to these minutes.

- O. Mrs. Doneghy offered and moved for adoption of the following resolution, with a second by Ms. Luetke:

Resolution No. 102-22 – Authorization of Issuance of Super Blanket Purchase Order to Enterprise Fleet Management

After discussion and upon unanimous vote the resolution was declared duly adopted and recorded in the appendix to these minutes.

- P. Ms. Luetke offered and moved for adoption of the following resolution, with a second by Mrs. Doneghy:

Resolution No. 103-22 – Issuance of Super Blanket Purchase Orders for 2023 Wayfinding Signage

After discussion and upon unanimous vote the resolution was declared duly adopted and recorded in the appendix to these minutes.

- Q. Mr. Dalton offered and moved for adoption of the following resolution, with a second by Mrs. Doneghy:

Resolution No. 104-22 – Ratification of Schedule of Payables

After discussion and upon unanimous vote the resolution was declared duly adopted and recorded in the appendix to these minutes.

- R. Mrs. Doneghy offered and moved for adoption of the following resolution, with a second by Ms. Luetke:

Resolution No. 105-22 – Contract Approval, Blue Creek Metropark Electrical Service Renovation

Mr. Brad Hooven indicated that this would cover the removal of utility poles that are at the end of their useful life and will move those utilities underground. Mr. Byers inquired as to why there was a large gap between the estimate and the ultimate quote; Mr. Hooven indicated that the flexible timeline and adjusted materials had an effect on the pricing.

After discussion and upon unanimous vote the resolution was declared duly adopted and recorded in the appendix to these minutes. Mr. Savage abstained from voting due to a conflict of interest.

- S. Mr. Byers offered and moved for adoption of the following resolution, with a second by Mrs. Doneghy:

Resolution No. 106-22 – Purchase Contract Increase Approval, Duncan and Grove

Mr. Hooven indicated that the final price was to be determined at time of delivery, which because of increases in international shipping, the overall cost has increased from the initially approved amount.

After discussion and upon unanimous vote the resolution was declared duly adopted and recorded in the appendix to these minutes.

- T. Mr. Dalton offered and moved for adoption of the following resolution, with a second by Mrs. Doneghy:

Resolution No. 107-22 – Contract Approval, Glass City Riverwalk Professional Construction Administration & Testing Services

Ms. Jennifer Van Horn indicated that this is specific to the BUILD Grant portion of the Glass City Riverwalk project. This fulfills a requirement from the Department of Transportation to engage in these professional services. All contractors were qualified and the lowest bid was selected per the set process.

After discussion and upon unanimous vote the resolution was declared duly adopted and recorded in the appendix to these minutes.

- U. Ms. Luetke offered and moved for adoption of the following resolution, with a second by Mr. Byers:

Resolution No. 108-22 – Purchase Approval, Zamboni Ice Resurfacer

Mr. Hooven indicated that the Metroparks team consulted with Rink Management Services and the Zamboni company to determine the appropriate options and model for the ice resurfacer; an electric option was chosen to increase the life expectancy of the machine.

After discussion and upon unanimous vote the resolution was declared duly adopted and recorded in the appendix to these minutes.

5. BOARD INITIATED TOPICS AND DISCUSSION

Mr. Savage recognized Ranger Tracy Gallagher who will be retiring from Metroparks Toledo at the end of the year. Ranger Gallagher has been with Metroparks Toledo since she was in high school, serving most of her 35 year career at Pearson Metropark. Mr. Savage expressed his gratitude on behalf of the Board of Commissioners for her service.

Ms. Luetke expressed a Happy Holidays to the entire Metroparks Toledo staff and recognized that there are staff members who work every day of the year, including holidays, which is appreciated by the community.

With no further business or action to be taken, Mr. Dalton made a motion to adjourn the Board meeting at 9:16 a.m., which was seconded by Mrs. Doneghy and approved.

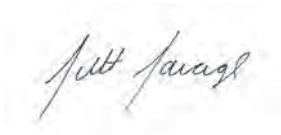

Scott Savage, President



Attest: _____
Dave Zenk, Executive Director

DDZ/bs
12/14/22



**METROPARKS
TOLEDO**

Administrative Office

Board Brief

5100 West Central Avenue
Toledo, Ohio 43615-2100

419.407.9700
Fax **419.407.9785**

MetroparksToledo.com

Meeting Date: January 18, 2023
Agenda Item: Treasurer's Report
Prepared By: Matt Cleland, Chief Financial Officer

DESCRIPTION:

Treasurer's Report containing:

1. Revenues, Expenditures and Changes in Fund Balances – Budget vs. Actual – General Fund -- as of December 31, 2022
2. Receipts, Disbursements and Changes in Fund Balances – Budget vs. Actual – All Funds -- as of December 31, 2022
3. Fund Advances Report as of December 31, 2022
4. Outstanding Debt Report as of December 31, 2022
5. Credit Card Account Review as of December 31, 2022
6. Investment Ledger as of December 31, 2022
7. Then & Now Report for the month ended December 31, 2022

RECOMMENDATION:

Move to accept Treasurer's Report

Chief Financial Officer

Supplementary Materials Attached

1. Revenues, Expenditures and Changes in Fund Balances – Budget vs. Actual – General Fund as of 12/31/2022

Description: This report is a comparison of the General Fund budgeted revenues, expenditures and transfers compared to actual revenues, expenditures and transfers by month as well as year-end. The approved 2022 general operating fund budget and actual cash basis revenues, expenditures and transfers are represented. Year to date budget distribution is based upon a 12 month proration with the exception of salaries and fringe benefits. Salary and fringe benefit budget distribution is based upon a proration of 26 pay dates. (See Appended Statement – Attachment A).

Current State: Tax revenue appears just slightly under projection. However the new debt service fund calls for a portion of tax revenue to be receipted into that fund. When combined, tax revenue exceeds projections. The other revenue category significantly exceeded projection with the receipt of one time property tax refunds.

Given economic changes and the current labor market salary and utility expenses exceeding their budget are not surprising. In total expenses ended the year eight percent under budget resulting in a fund balance that is on target.

2. Receipts, Disbursements and Changes in Fund Balances – Budget vs. Actual – All Funds as of 12/31/2022

Description: This report is a comparison of annual budgeted receipts and disbursements compared to cash basis actuals as of month end. The General, Education/Programming and Capital Construction funds are presented as individual columns. The “Grant Funds”, “Land Acquisition/Development” and “All Other Funds” columns are each summaries of multiple funds. The far right column is a total of all funds. General fund budget and actual numbers presented in this report are consistent with those presented in the report listed above. (See Appended Statement -- Attachment B).

Current State: The Education/Programming fund also experienced salaries in excess of the budget but finished the year with a positive fund balance. In the All Other Funds column contract services exceed budget due to reconciliation and reclassification of Buckeye fund expenses. The Buckeye fund has more than sufficient appropriations in other categories to support the reclassification.

3. Fund Advances Report – All Funds as of 12/31/2022

Description: This is a report of inter-fund, Board approved advances activity. Advances are made to support reimbursement grants and activities that would otherwise result in negative fund balances. Advances are returned following the receipt of grant reimbursement revenue.

Current State:

Date of Advance	Fund	Grant	Amount
December 2022	256	Federal Grants	\$1,570,1156
December 2022	257	State Grants	\$1,821,581
December 2022	258	Local and Other Grants	\$1,546,389

4. Outstanding Debt Report as of 12/31/2022

Metroparks outstanding debt is identified below.

Current State:

Metroparks Outstanding Debt					
Creditor	Current Interest Rate	Current Interest Charges	Principal Loan/Lease Amount	Total Payments to Date	Current Principal Balance Owed
Key Government Finance Inc.	2.982%	N/A	\$27,000,000.00	\$0.00	\$27,000,000.00

5. Credit Card Account Review as of 12/31/2022

Description: Per Ohio Revised Code 1545.072 the credit card compliance officer must review the number of cards and accounts issued, the number of active cards and accounts issued, the cards' and accounts' expiration dates, and the cards' and accounts' credit limits and report this information to the board at least quarterly. (See Appended Statement -- Attachment C)

Current State: Josh Brenwell, Credit Card Compliance Officer, has reviewed the attached report and compared it with credit card statements to confirm the accuracy of information provided.

No rewards have been received based on the use of the park district's credit card account for 2022.

6. Investment Ledger as of 12/31/2022

Description: This report is a listing of the Park District's current investment holdings. Current investments are allowable per the Ohio Revised Code and are laddered over a 5-year period. (See Appended Statement -- Attachment D).

Current State: One certificate of deposit matured in the month of December. The proceeds are in the money market account in anticipation of cash flow requirements.

7. Then and Now Report for the month ended 12/31/2022

Description: The Ohio Revised Code (ORC) requires fiscal certification indicating that amounts required for purchases, obligations, contracts, etc. have been lawfully appropriated and are in the treasury or in the process of collection to the credit of an appropriate fund free from any previous encumbrances. Then and now is a certification by the Board that funds were available when an obligation was made (then) and at the time of certification (now) for obligations made prior to certification. (See Appended Statement -- Attachments E).

Current State: There are six items requiring certification by the board for the month of December.

METROPOLITAN PARK DISTRICT OF THE TOLEDO AREA

Statement of Revenues, Expenditures and Changes

In Fund Balance - Budget vs. Actual

2022 General Fund

Report for the Period Ended December 31, 2022

	2022				
	12.31.2022	Actual	YTD Budget	Annual Budget	YTD Variance
	1	12	12	12 mos	12 mos
Beginning of Year Carryover Fund Balance	\$ 4,462,913	\$ 4,462,913	\$ 4,462,913	\$ 4,462,913	
Revenues					
Taxes	24,284	30,708,773.86	30,822,000	30,822,000	0%
Intergovernmental	67,224	2,971,190	2,994,332	2,994,332	-1%
Fines and Forfeitures	-	1,832	2,707	2,707	-32%
Charges for Services/Fees	59,791	1,050,309	880,000	880,000	19%
Sales	16,956	80,813	82,389	82,389	-2%
Donations	-	-	-	-	-
Interest Income	(14,202)	173,910	141,500	141,500	23%
All Other Revenue	141,554	657,157	377,513	377,513	74%
Total Revenues	295,607	35,643,986	35,300,441	35,300,441	1%
Expenditures					
Salaries	735,769	9,325,456	9,165,687	9,165,687	2%
Fringe Benefits	246,591	3,007,665	3,143,014	3,143,014	-4%
Materials & Supplies	102,405	981,010	1,290,492	1,290,492	-24%
Utilities	107,767	1,222,786	1,149,520	1,149,520	6%
Contract Services	375,951	4,050,504	5,122,700	5,122,700	-21%
Contingencies	-	-	219,500	219,500	-
Capital Outlay	1,843	160,215	162,700	162,700	-2%
Other	(29)	11,583	171,110	171,110	-93%
Total Expenditures	1,570,295.97	18,759,218.08	20,424,723	20,424,723	-8%
	(1,274,689)	16,884,767	14,875,718	14,875,718	
Other Financing Sources (Uses)					
Advances In	4,383,065	4,383,065	-	-	
Transfers In	-	-	-	-	
Transfers Out - Education Fund	-	(1,018,901)	(1,018,901)	(1,018,901)	
Transfers Out - Capital Construction Fund	-	(1,198,358)	(1,198,358)	(1,198,358)	
Transfers Out - Glass City Riverwalk Fund	-	(14,158,604)	(14,375,545)	(14,375,545)	
Transfers Out - Cannaley Treehouse	-	(45,000)	(45,000)	(45,000)	
Advances Out	(4,938,085)	(4,938,085)	-	-	
Total Other Financing Sources (Uses)	(555,020)	(16,975,883)	(16,637,804)	(16,637,804)	
Net Change in Fund Balance	(1,829,709)	(91,116)	(1,762,086)	(1,762,086)	
Fund Balance	\$ 2,633,204	\$ 4,371,797	\$ 2,700,827	\$ 2,700,827	

METROPOLITAN PARK DISTRICT OF THE TOLEDO AREA

*In Fund Balance -- Budget vs. Actual
For the Month Ended December 31, 2022*

	General		Education/Programming		Grant Funds		Debt Service		Land Acquisition/Development		Capital Construction		All Other Funds		TOTAL ALL FUNDS	
	Budget	Actual	Budget	Actual	Budget	Actual	Budget	Actual	Budget	Actual	Budget	Actual	Budget	Actual	Budget	Actual
Fund Balance Beginning of Year	\$ 4,462,913	\$ 4,465,843	\$ 294,254	\$ 294,254	\$ 2,312,682	\$ 2,312,682	\$ -	\$ -	\$ 608,410	\$ 608,410	\$ 17,980,720	\$ 17,980,720	\$ 4,507,070	\$ 4,507,070	\$ 30,166,049	\$ 30,168,979
Revenues																
Taxes	\$ 30,822,000	\$ 30,708,774	\$ -	\$ -	\$ -	\$ -	\$ -	\$ 216,941	\$ -	\$ -	\$ -	\$ -	\$ -	\$ -	\$ 30,822,000	\$ 30,925,714
Intergovernmental	\$ 2,994,332	\$ 2,971,190	\$ -	\$ -	\$ 14,617,914	\$ 7,457,918	\$ -	\$ -	\$ 20,000	\$ 101,411	\$ -	\$ 1,267,223	\$ -	\$ 10,000	\$ 17,632,246	\$ 11,807,742
Fines and Forfeitures	\$ 2,707	\$ 1,832	\$ -	\$ -	\$ -	\$ -	\$ -	\$ -	\$ -	\$ -	\$ -	\$ -	\$ 500	\$ 765	\$ 3,207	\$ 2,597
Charges for Services/Fees	\$ 880,000	\$ 1,050,309	\$ 225,000	\$ 183,212.21	\$ -	\$ -	\$ -	\$ -	\$ -	\$ -	\$ -	\$ -	\$ -	\$ -	\$ 1,105,000	\$ 1,233,522
Sales	\$ 82,389	\$ 80,813	\$ -	\$ -	\$ -	\$ -	\$ -	\$ -	\$ -	\$ -	\$ -	\$ -	\$ 5,000	\$ 20	\$ 87,389	\$ 80,833
Donations	\$ -	\$ -	\$ -	\$ 433.40	\$ -	\$ 31,253	\$ -	\$ -	\$ -	\$ -	\$ -	\$ -	\$ 695,000	\$ 2,393,374	\$ 695,000	\$ 2,425,060
Fees (Memberships)	\$ -	\$ 0	\$ -	\$ -	\$ -	\$ -	\$ -	\$ -	\$ -	\$ -	\$ -	\$ -	\$ -	\$ -	\$ -	\$ -
Interest Income	\$ 141,500	\$ 173,910	\$ -	\$ -	\$ -	\$ -	\$ -	\$ 111,372	\$ -	\$ -	\$ -	\$ -	\$ -	\$ 57,869	\$ 141,500	\$ 343,151
All Other Revenue	\$ 377,513	\$ 657,157	\$ 16,000	\$ 28,184	\$ -	\$ 29,173	\$ -	\$ -	\$ 434,786	\$ -	\$ -	\$ 20,013,275	\$ 2,000	\$ 5,822	\$ 830,299	\$ 20,733,610
Total Revenues	\$ 35,300,441	\$ 35,643,986	\$ 241,000	\$ 211,829.17	\$ 14,617,914	\$ 7,518,344	\$ -	\$ 328,312	\$ 454,786	\$ 101,411	\$ -	\$ 21,280,498	\$ 702,500	\$ 2,467,849	\$ 51,316,641	\$ 67,552,229
Expenditures																
Salaries	\$ 9,165,687	\$ 9,325,456	\$ 956,018	\$ 972,420.39	\$ 65,521	\$ 54,131	\$ -	\$ -	\$ -	\$ -	\$ 265,091	\$ 153,673	\$ 145,640	\$ 141,401	\$ 10,597,957	\$ 10,647,080.92
Fringe Benefits	\$ 3,143,014	\$ 3,007,665	\$ 323,824	\$ 326,242.68	\$ 24,550	\$ 9,347	\$ -	\$ -	\$ -	\$ -	\$ 81,141	\$ 36,697	\$ 65,949	\$ 58,019	\$ 3,638,478	\$ 3,437,970.60
Materials & Supplies	\$ 1,290,492	\$ 981,010	\$ 82,725	\$ 15,770.03	\$ 29,004	\$ 28,451	\$ -	\$ -	\$ -	\$ -	\$ -	\$ -	\$ 93,950	\$ 135,206	\$ 1,496,171	\$ 1,160,438.15
Utilities	\$ 1,149,520	\$ 1,222,786	\$ -	\$ -	\$ -	\$ -	\$ -	\$ -	\$ -	\$ -	\$ -	\$ -	\$ -	\$ -	\$ 1,149,520	\$ 1,222,786.68
Contract Services	\$ 5,122,700	\$ 4,050,504	\$ 57,125	\$ 55,248.39	\$ 4,443,738	\$ 4,385,418	\$ -	\$ -	\$ 116,760	\$ 16,049	\$ 3,591,438	\$ 1,066,790	\$ 321,044	\$ 544,022	\$ 13,652,805	\$ 10,118,031.79
Contingencies	\$ 219,500	\$ -	\$ -	\$ -	\$ -	\$ -	\$ -	\$ 228,270	\$ -	\$ -	\$ -	\$ -	\$ 450,000	\$ -	\$ 669,500	\$ 228,270.00
TBG Operations	\$ -	\$ -	\$ -	\$ -	\$ -	\$ -	\$ -	\$ -	\$ -	\$ -	\$ -	\$ -	\$ -	\$ -	\$ -	\$ -
Capital Outlay	\$ 162,700	\$ 160,215	\$ 50,000	\$ 40,694.95	\$ 8,724,602	\$ 5,396,625	\$ -	\$ -	\$ 494,974	\$ 253,896	\$ 11,854,124	\$ 27,751,102	\$ 972,607	\$ 397,850	\$ 22,259,007	\$ 34,000,383.01
Other	\$ 171,110	\$ 11,583	\$ 80,000	\$ 4,050.42	\$ 1,970	\$ 980	\$ -	\$ -	\$ -	\$ -	\$ -	\$ 6,812,233	\$ 124,400	\$ 66,460	\$ 377,480	\$ 6,895,307.02
Total Expenditures	\$ 20,424,723	\$ 18,759,218.08	\$ 1,549,692	\$ 1,414,426.86	\$ 13,289,385	\$ 9,874,953	\$ -	\$ 228,270	\$ 611,734	\$ 269,945	\$ 15,791,794	\$ 35,820,496	\$ 2,173,590	\$ 1,342,958	\$ 53,840,918	\$ 67,710,267
Excess of Revenues Over (Under) Ex	\$ 14,875,718	\$ 16,884,767	\$ (1,308,692)	\$ (1,202,598)	\$ 1,328,529	\$ (2,356,609)	\$ -	\$ 100,042	\$ (156,948)	\$ (168,534)	\$ (15,791,794)	\$ (14,539,998)	\$ (1,471,090)	\$ 1,124,891	\$ (2,524,277)	\$ (158,038)
Other Financing Sources (Uses)																
Transfers In	\$ -	\$ -	\$ 1,018,901	\$ 1,018,901	\$ -	\$ -	\$ -	\$ -	\$ -	\$ -	\$ 15,618,903	\$ 15,401,962	\$ -	\$ -	\$ 16,637,804	\$ 16,420,863
Advances In	\$ -	\$ 4,383,065	\$ -	\$ -	\$ -	\$ 4,938,085	\$ -	\$ -	\$ -	\$ -	\$ -	\$ -	\$ -	\$ -	\$ -	\$ 9,321,150
Transfers Out - Education	\$ (1,018,901)	\$ (1,018,901)	\$ -	\$ -	\$ -	\$ -	\$ -	\$ -	\$ -	\$ -	\$ -	\$ -	\$ -	\$ -	\$ (1,018,901)	\$ (1,018,901)
Transfers Out - Capital Construction	\$ (15,618,903)	\$ (1,198,358)	\$ -	\$ -	\$ -	\$ -	\$ -	\$ -	\$ -	\$ -	\$ -	\$ -	\$ -	\$ -	\$ (15,618,903)	\$ (1,198,358)
Transfers Out - Glass City Riverwalk	\$ -	\$ (14,158,604)	\$ -	\$ -	\$ -	\$ -	\$ -	\$ -	\$ -	\$ -	\$ -	\$ -	\$ -	\$ -	\$ -	\$ (14,158,604)
Transfers Out - Treehouse Village Fund	\$ -	\$ (45,000)	\$ -	\$ -	\$ -	\$ -	\$ -	\$ -	\$ -	\$ -	\$ -	\$ -	\$ -	\$ -	\$ -	\$ (45,000)
Advances Out	\$ -	\$ (4,938,085)	\$ -	\$ -	\$ -	\$ (4,383,065)	\$ -	\$ -	\$ -	\$ -	\$ -	\$ -	\$ -	\$ -	\$ -	\$ (9,321,150)
Total Other Financing Sources (Uses)	\$ (16,637,804)	\$ (16,975,883)	\$ 1,018,901	\$ 1,018,901	\$ -	\$ 555,020	\$ -	\$ -	\$ -	\$ -	\$ 15,618,903	\$ 15,401,962	\$ -	\$ -	\$ -	\$ -
Net Change in Fund Balance	\$ (1,762,086)	\$ (91,116)	\$ (289,791)	\$ (183,697)	\$ 1,328,529	\$ (1,801,589)	\$ -	\$ 100,042	\$ (156,948)	\$ (168,534)	\$ (172,891)	\$ 861,964	\$ (1,471,090)	\$ 1,124,891	\$ (2,524,277)	\$ (158,038)
Fund Balance	\$ 2,700,827	\$ 4,374,728	\$ 4,463	\$ 110,557	\$ 3,641,211	\$ 511,093	\$ -	\$ 100,042	\$ 451,462	\$ 439,877	\$ 17,807,829	\$ 18,842,684	\$ 3,035,980	\$ 5,631,961	\$ 27,641,772	\$ 30,010,941

METROPOLITAN PARK DISTRICT OF THE TOLEDO AREA
 CREDIT CARD ACCOUNT REVIEW
 12/31/2022

Cardholder Name	Account Status	Credit Limit	Expiration Date
ALLEN GALLANT	Open	\$2,500.00	Nov-26
AMY MOSSING	Open	\$3,000.00	Nov-24
ANTHONY W AMSTUTZ	Open	\$6,000.00	Nov-24
ASHLEY R SMITH	Open	\$3,500.00	Nov-26
BETHANY A SATTLER	Open	\$3,000.00	Nov-23
BRAD HOOVEN	Open	\$6,000.00	Nov-26
BRAD NAVARRE	Open	\$5,000.00	Nov-24
BRANDON DERAN	Open	\$3,000.00	Nov-26
BRIAN POLLICK	Open	\$3,500.00	Nov-24
CARRIE A HADDIX	Open	\$1,500.00	Nov-23
CONSTRUCTION CREW	Open	\$10,000.00	Nov-26
CRAIG ELTON	Open	\$5,000.00	Nov-26
DAVE D ZENK	Open	\$5,000.00	Nov-24
DAWN DICKERSON	Open	\$3,000.00	Nov-26
DENIS A FRANKLIN	Open	\$5,000.00	Nov-23
DEVIN CONNOLLY	Open	\$5,000.00	Nov-26
EFFLER ALLY	Open	\$3,000.00	Nov-26
EMILY MAIN	Open	\$5,000.00	Nov-26
FARNSWORTH PARK	Open	\$4,000.00	Nov-26
FELICA CLARK	Open	\$5,500.00	Nov-25
GLASS CITY METROPARK	Open	\$6,000.00	Nov-25
GRAEM BOYER	Open	\$5,000.00	Nov-25
GREG MAHLMAN	Open	\$1,500.00	Nov-26
HEATHER MOSQUEDA	Open	\$5,000.00	Nov-25
JACQUELINE CUMMINS	Open	\$3,000.00	Nov-26
JAMES CASSIDY	Open	\$3,000.00	Nov-24
JENNIFER VAN HORN	Open	\$4,000.00	Nov-26
JESSICA SCHAEFER	Open	\$3,000.00	Nov-26
JILL MOLNAR	Open	\$4,000.00	Nov-24
JON R ZVANOVEC	Open	\$5,000.00	Nov-25
KATHRYN SMITH	Open	\$3,000.00	Nov-25
KAYLAH JOHNSON	Open	\$3,000.00	Nov-26
KERRI WHITEMAN	Open	\$3,500.00	Nov-26
KEVIN COLLINS	Open	\$7,000.00	Nov-25
LARAE SPROW	Open	\$5,000.00	Nov-25
LISA WHITTON	Open	\$6,000.00	Nov-26
LORI MILLER	Open	\$5,000.00	Nov-23
MACKENZIE HUBER	Open	\$8,000.00	Nov-25
MATT CLELAND	Open	\$1,500.00	Nov-25
MATT KILLAM	Open	\$3,500.00	Nov-25
METROPARKS TOLEDO	Open	\$3,500.00	Nov-26
METROPARKS TOLEDO AREA	Open	\$3,000.00	Nov-25
MICHAEL KEEDY	Open	\$3,000.00	Nov-26
MORGAN SOPKO	Open	\$3,000.00	Nov-26

METROPOLITAN PARK DISTRICT OF THE TOLEDO AREA
CREDIT CARD ACCOUNT REVIEW
12/31/2022

NATE RAMSEY	Open	\$6,000.00	Nov-24
OAK OPENINGS METROPARK	Open	\$3,500.00	Nov-23
OPERATIONS BLUE CREEK	Open	\$3,000.00	Nov-26
PATRICIA M HAUSKNECHT	Open	\$2,500.00	Nov-25
PATTY MORGENSTERN	Open	\$5,000.00	Nov-25
PEARSON METROPARK	Open	\$5,000.00	Nov-25
ROBERT HECKMAN	Open	\$5,000.00	Nov-24
RUTH GRIFFIN	Open	\$6,000.00	Nov-24
SAMUEL WILHELM	Open	\$3,500.00	Nov-26
SCOTT CARPENTER	Open	\$1,500.00	Nov-25
STACI STASIAK	Open	\$3,000.00	Nov-26
STARR SEMRAU	Open	\$3,000.00	Nov-25
STEVE STOCKFORD	Open	\$5,000.00	Nov-25
TIM GALLAHER	Open	\$4,000.00	Nov-25
TIM SCHETTER	Open	\$3,000.00	Nov-25
TOLEDO AREA METROPARKS	Open	\$3,000.00	Nov-24
TOLEDO AREA METROPARKS	Open	\$3,000.00	Nov-24
TOLEDO AREA METROPARKS	Open	\$5,000.00	Nov-24
VALERIE JUHASZ	Open	\$6,000.00	Nov-24
VOLUNTEER SERVICES	Open	\$3,000.00	Nov-25
ZACHARY BECKER	Open	\$3,000.00	Nov-26
ZURIJANNE CARTER	Open	\$3,000.00	Nov-26

METROPOLITAN PARK DISTRICT OF THE TOLEDO AREA
INVESTMENT LEDGER
December 31, 2022

CUISP or ID NUMBER	FACE / INVESTABLE AMOUNT	INTEREST RATE	PURCHASE DATE	MATURITY / CALL DATE	INTEREST PAYMENTS	PURCHASE AMOUNT
BANK CASH MANAGEMENT						
Fifth Third						153,074.30
Huntington						108,913.05
Signature 125						4,798.61
Signature Checking						6,951,870.12
Signature Hankison						-
Signature Bond (Investment Savings)						6,385,992.41
SIGNATURE BANK -- Hankison Endowment Fund						
<i>Certificate of Deposit</i>						162,390
UBS FINANCIAL						
<i>Government Securities</i>						
3130APKL8	\$220,000	0.75%	11/08/21	02/08/22	Semi-Ann	219,863.60
3130AQ5	\$140,000	1.10%	01/01/21	12/30/24	Semi-Ann	139,951.00
3133ENGW4	\$100,000	0.67%	02/17/22	12/13/23	Semi-Ann	98,524.17
3130AQVT7	\$260,000	1.60%	02/09/22	08/27/24	Semi-Ann	259,935.00
912828ZD5	\$250,000	0.50%	03/18/22	03/15/23	Semi-Ann	248,028.19
91282CBE0	\$250,000	0.13%	03/18/22	01/15/24	Semi-Ann	242,067.83
912828B66	\$150,000	2.75%	03/29/22	02/15/24	Semi-Ann	151,644.29
912828Z29	\$240,000	1.50%	04/13/22	01/15/23	Semi-Ann	240,866.33
91282CEK3	\$350,000	2.50%	07/19/22	04/30/24	Semi-Ann	347,704.90
3130ASQP7	\$250,000	3.63%	07/19/22	01/28/25	Semi-Ann	249,962.50
3130AMMM1	\$130,000	0.38%	08/16/22	06/03/24	Semi-Ann	123,340.21
91282CER8	\$245,000	2.50%	08/30/22	05/31/24	Semi-Ann	242,587.08
91282CFA4	\$260,000	3.00%	11/21/22	07/31/24	Semi-Ann	255,489.74
91282CCD1	\$135,000	0.13%	11/07/22	05/31/23	Semi-Ann	131,814.79
<i>Certificates of Deposit and Shared Certificates</i>						
649447VM8	\$248,000	1.50%	04/13/22	01/15/23	Semi-Ann	237,205.68
538036IA3	\$240,000	1.65%	03/03/20	02/13/23	Monthly	242,777.09
20056QRU9	\$240,000	2.75%	07/31/19	04/10/23	Monthly	245,542.68
949763ZL3	\$150,000	2.70%	03/31/20	04/12/23	Monthly	154,198.68
25665QAX3	\$115,000	2.90%	08/22/19	04/13/23	Semi-Ann	118,402.47
87164WWA2	\$230,000	3.05%	04/03/19	05/04/23	Semi-Ann	232,907.87
254673QR0	\$240,000	3.30%	05/14/19	06/27/23	Semi-Ann	245,197.37
61747M4Z1	\$250,000	3.30%	08/07/18	08/16/23	Semi-Ann	250,000.00
956320AH9	\$236,000	3.25%	07/29/19	09/28/23	Semi-Ann	246,280.37
27002YEX0	\$150,000	1.55%	04/22/20	03/30/24	Monthly	153,000.00
38148P2K2	\$232,000	3.60%	11/19/21	11/28/23	Monthly	249,423.45
<i>Cash and Money Market Funds</i>						
27772						272,715.64
UBS FINANCIAL -- Gallon Trail Endowment Fund						
<i>Cash and Money Market Funds</i>						
27773						1,106,574.98
UBS FINANCIAL -- DW 30600 M2						
<i>Cash and Money Market Funds</i>						
30600						6,218,577.95
OHIO STATE TREASURER						
<i>State Treasury Asset Reserve of Ohio (STAR)</i>						
STAR76354					Monthly	236,140
STAR76668					Monthly	2,036,803
FIFTH THIRD -- Money Market Navigator						
<i>Money Market Funds</i>						
1885071517						1,046,376
						\$30,010,941

METROPOLITAN PARK DISTRICT OF THE TOLEDO AREA
Then & Now Report
For the Month Ended December 31, 2022

Payment Date	Check Number	Amount	Vendor	Account Number	Purchase Order	PO Date	Invoice Date	Days in Violation	Invoice Line Description
12/23/2022	9903	\$ 9,167.13	04012 (Telesystem)	100.3003.540700	2022003051	12/6/2022	12/1/2022	5	IS_Telesystem utility invoice
12/9/2022	67344	\$ 50,000.00	07881 (GRAPHITE DESIGN + BUILD LIMITED)	404.9000.551900	2022002903	11/28/2022	11/2/2022	26	PH_Glass City Donor Recognition Wall Design and Co
12/16/2022	67364	\$ 50,000.00	5694 (Rink Management Services)	100.6009.551901	2022003048	12/6/2022	12/1/2022	5	GC_rink operating costs
12/9/2022	6021199	\$ 3,600.00	4631 (Coleman Systems, Inc.)	100.6007.558300	2022003002	11/30/2022	11/25/2022	5	WW_HVAC PMs
12/16/2022	6021278	\$ 137,369.52	08459 (The Lathrop Company)	404.5122.572000	2022002855	11/21/2022	11/15/2022	6	PC_GC Enrichment Center CMAR Services - Construction
12/23/2022	6021306	\$ 19,560.00	5421 (Duncan & Grove USA Ltd.)	404.5001.572000	2022003159	12/9/2022	11/15/2022	24	PC_GC_Prairie Pollinator Additional Freight Charge



**METROPARKS
TOLEDO**
Administrative Office

Board Brief

5100 West Central Avenue
Toledo, Ohio 43615-2100

419.407.9700
Fax **419.407.9785**

MetroparksToledo.com

Meeting Date: January 18, 2023

Agenda Item: Approval of Supplement and Amendment of the 2023 Certificate of Estimated Resources and Appropriations Measure

Prepared By: Matt Cleland, Chief Financial Officer

DESCRIPTION:

The 2023 Annual Appropriations Measure was approved by the Board at the November 2022 Board Meeting and subsequently amended. Additional supplements to the 2023 Certificate of Estimated Resources and Appropriations Measure are needed to address supplements as summarized below. The affected line item appropriations and Certificate of Estimated Resources are attached.

The affected funds are as follows:

Fund 202 – Buckeye

Increase appropriations in the amount of \$2,177,149. to support various donation supported initiatives . This increase brings the total of appropriations in fund 202 to \$2,553,516.

Fund 256 - Christopher & Dana Reeve Foundation - Metroparks Toledo Adaptive Equipment

Increase appropriations in the amount of \$781. to support the purchase of adaptive program equipment. This increase brings the total of appropriations in fund 256 to \$29,564,375.

Fund 400 – Capital Construction

Increase appropriations in the amount of \$225,000. to district wide signage and gunite wingwall repair at Providence Metropark. This increase brings the total of appropriations in fund 400 to \$1,924,096.

RECOMMENDATION:

Approve 2023 Supplementing Appropriations Measure in the amount of \$91,318,463.00.

Supplementary Materials Attached

METROPOLITAN PARK DISTRICT OF THE TOLEDO AREA
2023 SUPPLEMENT TO CERTIFICATE OF ESTIMATED RESOURCES BY LINE ITEM
January 18, 2023

Fund 256 - Christopher & Dana Reeve Foundation - Metroparks Toledo Adaptive Equipment

Revenue Acct. #	Project #	Description	Current Budget	Adjustment Amount	Revised Budget
256.8032.421000	223407006	FEDERAL GRANTS	\$ -	\$ 781	\$ 781
		Total	\$ -	\$ 781	\$ 781

METROPOLITAN PARK DISTRICT OF THE TOLEDO AREA
2023 APPROPRIATIONS SUPPLEMENT BY LINE ITEM ACCOUNT
January 18, 2023

Fund 202 - Buckeye Fund

Expense Acct. #	Project #	Description	Current Budget	Adjustment Amount	Revised Budget
202.1003.551900	Various	MISC CONTRACT SVCS - DEI	\$ -	\$ 5,068	\$ 5,068
202.2000.580200	Various	CONTINGENCY - DW	\$ -	\$ 4,736	\$ 4,736
202.3001.550100	Various	Conferences/Training - ES	\$ -	\$ 1,500	\$ 1,500
202.3003.551900	Various	MISC CONTRACT SVCS - IS	\$ -	\$ 13,660	\$ 13,660
202.4000.551900	Various	MISC CONTRACT SVCS - MKTG	\$ -	\$ 12,125	\$ 12,125
202.4006.551900	Various	MISC CONTRACT SVCS - SPV	\$ -	\$ 25,000	\$ 25,000
202.5001.551900	Various	MISC CONTRACT SVCS	\$ -	\$ 124,951	\$ 124,951
202.5001.551901	Various	MISC CONTRACT SVCS	\$ -	\$ 5,666	\$ 5,666
202.5001.570200	Various	LAND IMPROVEMENTS - PC	\$ -	\$ 600,000	\$ 600,000
202.5001.572700	Various	TRAILS - PC	\$ -	\$ 102,559	\$ 102,559
202.5001.572900	Various	MISC INFRASTRUCTURE - PC	\$ -	\$ 10,000	\$ 10,000
202.6000.530900	Various	OTHER OPERATIONAL EXPENDITURES - OPS	\$ -	\$ 50,000	\$ 50,000
202.6001.580900	Various	OTHER OPERATIONAL EXPENDITURES - PE	\$ -	\$ 314,020	\$ 314,020
202.6002.530100	Various	SM EQUIP/ FURN/ FIXTURES - SI	\$ -	\$ 26,410	\$ 26,410
202.6003.580900	Various	OTHER OPERATIONAL EXPENDITURES - FA	\$ -	\$ 23,515	\$ 23,515
202.6004.575100	Various	MISC CAP. O/LAY-AREA IMPROVEMENTS	\$ -	\$ 108,921	\$ 108,921
202.6006.551900	Various	MISC CONTRACT SVCS - SW	\$ -	\$ 124,354	\$ 124,354
202.6007.551900	Various	MISC CONTRACT SVCS - WW	\$ -	\$ 143,945	\$ 143,945
202.6008.551900	Various	MISC CONTRACT SVCS - BC	\$ -	\$ 4,715	\$ 4,715
202.6009.551900	Various	MISC CONTRACT SVCS - GC	\$ -	\$ 15,116	\$ 15,116
202.6010.551900	Various	MISC CONTRACT SERVICES - TBG	\$ -	\$ 200,183	\$ 200,183
202.7000.551900	Various	MISC CONTRACT SVCS - NR	\$ -	\$ 56,779	\$ 56,779
202.7000.551901	Various	MISC CONTRACT SVCS - NR	\$ -	\$ 110,600	\$ 110,600
202.7000.551902	Various	MISC CONTRACT SVCS - NR	\$ -	\$ 45,304	\$ 45,304
202.7000.551903	Various	MISC CONTRACT SVCS - NR	\$ -	\$ 220	\$ 220
202.7002.570100	Various	LAND PURCHASE - LA	\$ -	\$ 5,000	\$ 5,000
202.8002.530900	Various	OTHER OP MTRLS & SUPPLIES - PUBLIC PROGI	\$ -	\$ 25,416	\$ 25,416
202.8003.530900	Various	MTRLS & SUPPLIES - PRG	\$ -	\$ 17,386	\$ 17,386
		Total	\$ -	\$ 2,177,149	\$ 2,177,149

Fund 256 - Christopher & Dana Reeve Foundation - Metroparks Toledo Adaptive Equipment

Expense Acct. #	Project #	Description	Current Budget	Adjustment Amount	Revised Budget
256.8032.533700	223407006	M&S EQUIP	\$ -	\$ 781	\$ 781
		Total	\$ -	\$ 781	\$ 781

Fund 400 - Capital Construction

Expense Acct. #	Project #	Description	Current Budget	Adjustment Amount	Revised Budget
400.5058.572900	N/A	DW TRAIL SIGNAGE	\$ -	\$ 75,000	\$ 75,000
400.5001.572900	N/A	MISC INFRASTRUCTURE - PC	\$ 502,000	\$ 150,000	\$ 652,000
		Total	\$ 502,000	\$ 225,000	\$ 727,000



	100 General	200 Land Acquisition Levy	201 Cardinal	202 Buckeye
BEGINNING BALANCE				
<i>Estimated</i>	\$ 4,681,374	\$ 39,235	\$ 250,461	\$ 3,785,684
<i>Fund Balance as of 1/1/2023</i>				
ESTIMATED REVENUES				
Taxes	27,074,076	-	-	-
Intergovernmental	3,125,275	-	-	-
Fines and Forfeitures	2,734	-	-	-
Charges for Services/Fees	1,183,800	-	-	-
Sales	334,334	-	-	-
Donations	-	-	-	50,000
Interest Income	229,302	-	-	-
All Other Revenue	500,000	-	-	-
<i>Total Estimated Revenues</i>	<u>32,449,521</u>	<u>-</u>	<u>-</u>	<u>50,000</u>
APPROPRIATIONS				
Salaries	\$ 10,405,505	\$ -	\$ 133,344	\$ -
Fringe Benefits	3,381,789	-	38,674	-
Materials & Supplies	1,271,585	-	-	119,212
Utilities	1,427,120	-	-	-
Contract Services	5,324,234	-	-	944,186
Debt Payments	-	-	-	21,367
Contingencies	219,600	-	-	304,736
Capital Outlay	152,100	39,235	-	826,480
Other	164,610	-	10,000	337,535
<i>Total Appropriations</i>	<u>\$ 22,346,543</u>	<u>\$ 39,235</u>	<u>\$ 182,018</u>	<u>\$ 2,553,516</u>
Excess of Estimated Revenues <i>Over (Under) Appropriations</i>	10,102,978	(39,235)	(182,018)	(2,503,516)
OTHER FINANCING SOURCES (USES)				
Transfers In	-	-	-	-
Advances In	-	-	-	-
Transfers Out - Education	(1,021,901)	-	-	-
Transfers Out - Capital Construction	(9,250,405)	-	-	-
Advances Out	-	-	-	-
<i>Total Other Financing Sources (Uses)</i>	<u>(10,272,306)</u>	<u>-</u>	<u>-</u>	<u>-</u>
<i>Net Change in Fund Balance</i>	(169,328)	(39,235)	(182,018)	(2,503,516)
<i>Est. Fund Balance as of 12/31/2023</i>	<u>\$ 4,512,046</u>	<u>\$ -</u>	<u>\$ 68,443</u>	<u>\$ 1,282,168</u>



	203 Law Enforcement	204 Education	205 Members	256 Federal Grants
BEGINNING BALANCE				
<i>Estimated</i>	\$ 10,272	\$ 87,320	\$ 29,623	\$ 1
<i>Fund Balance as of 1/1/2023</i>				
ESTIMATED REVENUES				
Taxes	-	-	-	-
Intergovernmental	-	-	-	29,564,375
Fines and Forfeitures	500	-	-	-
Charges for Services/Fees	-	175,000	-	-
Sales	-	-	-	-
Donations	-	-	25,000	-
Interest Income	-	-	-	-
All Other Revenue	-	27,000	-	-
<i>Total Estimated Revenues</i>	<u>500</u>	<u>202,000</u>	<u>25,000</u>	<u>29,564,375</u>
APPROPRIATIONS				
Salaries	\$ -	\$ 866,264	\$ -	\$ 89,380
Fringe Benefits	-	\$ 313,844	-	38,333
Materials & Supplies	10,000	\$ 67,500	5,250	16,981
Utilities	-	\$ -	-	-
Contract Services	-	\$ 52,500	1,500	4,695,000
Debt Payments	-	\$ -	-	-
Contingencies	-	\$ -	-	-
Capital Outlay	-	\$ 10,000	-	24,724,681
Other	-	\$ 1,000	19,000	-
<i>Total Appropriations</i>	<u>\$ 10,000</u>	<u>\$ 1,311,108</u>	<u>\$ 25,750</u>	<u>\$ 29,564,375</u>
Excess of Estimated Revenues <i>Over (Under) Appropriations</i>	(9,500)	(1,109,108)	(750)	-
OTHER FINANCING SOURCES (USES)				
Transfers In	-	1,021,901	-	-
Advances In	-	-	-	-
Transfers Out - Education	-	-	-	-
Transfers Out - Capital Construction	-	-	-	-
Advances Out	-	-	-	-
<i>Total Other Financing Sources (Uses)</i>	<u>-</u>	<u>1,021,901</u>	<u>-</u>	<u>-</u>
<i>Net Change in Fund Balance</i>	(9,500)	(87,207)	(750)	-
<i>Est. Fund Balance as of 12/31/2023</i>	<u>\$ 772</u>	<u>\$ 113</u>	<u>\$ 28,873</u>	<u>\$ 1</u>



	257	258	300	400
	State Grants	Local and Other Grants	Debt Service	Capital Construction
BEGINNING BALANCE				
<i>Estimated</i>	\$ 1	\$ 1	\$ -	\$ 1,331,994
<i>Fund Balance as of 1/1/2023</i>				
ESTIMATED REVENUES				
Taxes	-	-	3,845,140	-
Intergovernmental	1,963,403	-	-	-
Fines and Forfeitures	-	-	-	-
Charges for Services/Fees	-	-	-	-
Sales	-	-	-	-
Donations	-	21,212	-	-
Interest Income	-	-	-	-
All Other Revenue	-	-	-	-
<i>Total Estimated Revenues</i>	<u>1,963,403</u>	<u>21,212</u>	<u>3,845,140</u>	<u>-</u>
APPROPRIATIONS				
Salaries	\$ -	\$ -	\$ -	\$ -
Fringe Benefits	-	-	-	-
Materials & Supplies	-	-	-	-
Utilities	-	-	-	-
Contract Services	1,037,057	21,212	-	171,400
Debt Payments	-	-	3,845,140	-
Contingencies	-	-	-	-
Capital Outlay	926,346	-	-	1,752,696
Other	-	-	-	-
<i>Total Appropriations</i>	<u>\$ 1,963,403</u>	<u>\$ 21,212</u>	<u>\$ 3,845,140</u>	<u>\$ 1,924,096</u>
Excess of Estimated Revenues <i>Over (Under) Appropriations</i>	-	-	-	(1,924,096)
OTHER FINANCING SOURCES (USES)				
Transfers In	-	-	-	775,000
Advances In	-	-	-	-
Transfers Out - Education	-	-	-	-
Transfers Out - Capital Construction	-	-	-	-
Advances Out	-	-	-	-
<i>Total Other Financing Sources (Uses)</i>	<u>-</u>	<u>-</u>	<u>-</u>	<u>775,000</u>
<i>Net Change in Fund Balance</i>	-	-	-	(1,149,096)
<i>Est. Fund Balance as of 12/31/2023</i>	<u>\$ 1</u>	<u>\$ 1</u>	<u>\$ -</u>	<u>\$ 182,898</u>



	401 Land Development	402 Wetland Mitigation	403 Treehouse Capital	404 Glass City River Walk
BEGINNING BALANCE				
<i>Estimated</i>	\$ 75,000	\$ 73,361	\$ 90,000	\$ 11,833,381
<i>Fund Balance as of 1/1/2023</i>				
ESTIMATED REVENUES				
Taxes	-	-	-	-
Intergovernmental	-	-	-	-
Fines and Forfeitures	-	-	-	-
Charges for Services/Fees	-	-	-	-
Sales	-	-	-	-
Donations	-	-	-	-
Interest Income	-	-	-	-
All Other Revenue	-	-	-	-
<i>Total Estimated Revenues</i>	<u>-</u>	<u>-</u>	<u>-</u>	<u>-</u>
APPROPRIATIONS				
Salaries	\$ -	\$ -	\$ -	\$ 189,391
Fringe Benefits	-	-	-	54,784
Materials & Supplies	-	-	-	-
Utilities	-	-	-	-
Contract Services	75,000	73,361	135,000	82,200
Debt Payments	-	-	-	-
Contingencies	-	-	-	-
Capital Outlay	-	-	-	16,637,411
Other	-	-	-	-
<i>Total Appropriations</i>	<u>\$ 75,000</u>	<u>\$ 73,361</u>	<u>\$ 135,000</u>	<u>\$ 16,963,786</u>
Excess of Estimated Revenues <i>Over (Under) Appropriations</i>	(75,000)	(73,361)	(135,000)	(16,963,786)
OTHER FINANCING SOURCES (USES)				
Transfers In	300,000	-	45,000	8,130,405
Advances In	-	-	-	-
Transfers Out - Education	-	-	-	-
Transfers Out - Capital Construction	-	-	-	-
Advances Out	-	-	-	-
<i>Total Other Financing Sources (Uses)</i>	<u>300,000</u>	<u>-</u>	<u>45,000</u>	<u>8,130,405</u>
<i>Net Change in Fund Balance</i>	225,000	(73,361)	(90,000)	(8,833,381)
<i>Est. Fund Balance as of 12/31/2023</i>	<u>\$ 300,000</u>	<u>\$ -</u>	<u>\$ -</u>	<u>\$ 3,000,000</u>



	500 Hankison Endowment	600 Retail Operations	Total All Funds
BEGINNING BALANCE			
<i>Estimated</i>	\$ 152,557	\$ 12,666	\$ 22,452,931
<i>Fund Balance as of 1/1/2023</i>			
ESTIMATED REVENUES			
Taxes	-	-	30,919,216
Intergovernmental	-	-	34,653,053
Fines and Forfeitures	-	-	3,234
Charges for Services/Fees	-	-	1,358,800
Sales	-	-	334,334
Donations	-	-	96,212
Interest Income	-	-	229,302
All Other Revenue	-	-	527,000
<i>Total Estimated Revenues</i>	<u>-</u>	<u>-</u>	<u>68,121,151</u>
APPROPRIATIONS			
Salaries	\$ -	\$ -	\$ 11,683,884
Fringe Benefits	-	-	3,827,424
Materials & Supplies	-	10,000	1,500,528
Utilities	-	-	1,427,120
Contract Services	-	2,614	12,615,264
Debt Payments	-	-	3,866,507
Contingencies	-	-	524,336
Capital Outlay	-	-	45,068,949
Other	-	-	532,145
<i>Total Appropriations</i>	<u>\$ -</u>	<u>\$ 12,614</u>	<u>\$ 81,046,157</u>
Excess of Estimated Revenues <i>Over (Under) Appropriations</i>	-	(12,614)	(12,925,006)
OTHER FINANCING SOURCES (USES)			
Transfers In	-	-	10,272,306
Advances In	-	-	-
Transfers Out - Education	-	-	(1,021,901)
Transfers Out - Capital Construction	-	-	(9,250,405)
Advances Out	-	-	-
<i>Total Other Financing Sources (Uses)</i>	<u>-</u>	<u>-</u>	<u>-</u>
<i>Net Change in Fund Balance</i>	-	(12,614)	(12,925,006)
<i>Est. Fund Balance as of 12/31/2023</i>	<u>\$ 152,557</u>	<u>\$ 52</u>	<u>\$ 9,527,925</u>

METROPOLITAN PARK DISTRICT OF THE TOLEDO AREA

_____ offered and moved adoption of the following resolution:

RESOLUTION NO. 01-23

APPROVAL OF SUPPLEMENT AND AMENDMENT OF THE 2023 CERTIFICATE OF ESTIMATED RESOURCES AND APPROPRIATIONS MEASURE

WHEREAS, the 2023 Certificate of Estimated Resources and Appropriations Measure was initially approved by the Board of Park Commissioners at the November 2022 Board Meeting, AND,

WHEREAS, amendments to the Certificate of Estimated Resources and Appropriations Measure require approval of the Board of Park Commissioners, AND,

WHEREAS, certain amendments and supplements to the 2023 Certificate of Estimated Resources and Appropriations Measure are proposed to address updates for grant programs as identified in the supplements attached hereto, NOW, THEREFORE,

BE IT RESOLVED, the Board of Park Commissioners hereby approves the attached amended and supplemental 2023 Certificate of Estimated Resources totaling \$100,846,388.00 and Appropriations Measure totaling \$91,318,463.00.

_____ seconded the motion and upon _____ vote the resolution was declared duly adopted and recorded in the appendix to these minutes.

CERTIFICATION

I hereby certify the foregoing to be a true and correct copy of a resolution duly adopted at the regular board meeting of the Metropolitan Park District of the Toledo Area held on January 18, 2023.

David D. Zenk
Executive Director

Approved as to Form:

(Amy Natyshak)
Attorney for the Board
January 18, 2023



**METROPARKS
TOLEDO**
Administrative Office

Board Brief

5100 West Central Avenue
Toledo, Ohio 43615-2100

419.407.9700
Fax **419.407.9785**

MetroparksToledo.com

Meeting Date: January 18, 2023

Agenda Item: Amendment to Board Resolution No. 96-22,
“Authorization of Amendment 96-22 for the Purchase of
General Liability, Etc. Insurance Coverage from Hylant
Administrative Services”

Prepared By: Matt Cleland, Chief Financial Officer

DESCRIPTION:

At the December 2022 Board Meeting, by Resolution No. 96-22, the Board of Park Commissioners approved the issuance of a super blanket purchase order not to exceed \$185,000.00 for the purchase of insurance services in 2023. The 2023 general liability renewal has been received with a premium of \$184,400.00. Additional Metroparks policies such as volunteer and drone insurance will cause the total due Hylant Administrative Services in 2023 to exceed \$185,000.00. Additional approval is necessary to cover additional expenditures with Hylant Administrative Services.

RECOMMENDATION:

Approve an amendment to Resolution No. 96-22 that increases the total amount to \$200,000.00 for the purchase of insurance services through Hylant Administrative Services in 2023.

METROPOLITAN PARK DISTRICT OF THE TOLEDO AREA

_____ offered and moved adoption of the following resolution:

RESOLUTION NO. 02-23

AMENDMENT TO RESOLUTION NO. 96-22, "AUTHORIZATION OF AMENDMENT 96-22 FOR THE PURCHASE OF GENERAL LIABILITY, ETC. INSURANCE COVERAGE FROM HYLANT ADMINISTRATIVE SERVICES"

WHEREAS, the Park District purchases general liability, etc. insurance coverage from Hylant Administrative Services for the District, AND,

WHEREAS, as identified in the 2022 Annual Appropriations Measure, projected costs for 2023 Park District insurance services were \$185,000.00, and, therefore, required Board approval for issuance of a super blanket purchase order, AND,

WHEREAS, at the December 2022 Board Meeting, by Resolution No. 96-22, the Board of Park Commissioners approved the issuance of a super blanket purchase order for 2023, payable to Hylant Administrative Services for 2023 Park District insurance coverage, in an amount not to exceed \$185,000.00, AND,

WHEREAS, the price of coverage has increased for 2023 and caused the total projected costs for 2023 to exceed \$185,000.00, NOW, THEREFORE,

BE IT RESOLVED, that the Board of Park Commissioners hereby approves an amendment to Resolution No. 96-22 increasing the total amount not to exceed to \$200,000.00 for the purchase of insurance coverage from Hylant Administrative Services.

_____ seconded the motion and upon _____ vote the resolution was declared duly adopted and recorded in the appendix to these minutes.

CERTIFICATION

I hereby certify the foregoing to be a true and correct copy of a resolution duly adopted at the regular board meeting of the Metropolitan Park District of the Toledo Area held on January 18, 2023.

David D. Zenk
Executive Director

Approved as to Form:

(Amy Natyshak)
Attorney for the Board
January 18, 2023

METROPOLITAN PARK DISTRICT OF THE TOLEDO AREA

_____ offered and moved adoption of the following resolution:

RESOLUTION NO. 03-23

RATIFICATION OF SCHEDULE OF PAYABLES

WHEREAS, the Metropolitan Park District of the Toledo Area Board of Park Commissioners, Lucas County, Ohio, wishes to ratify its payments on certain accounts listed on the Schedule of Payables for the month of December 2022, NOW THEREFORE,

BE IT RESOLVED, that the Board of Park Commissioners hereby approves the payments listed on the Schedule of Payables for the month of December 2022, in the amount of \$6,304,603.75.

_____ seconded the motion and upon _____ vote the resolution was declared duly adopted and recorded in the appendix to these minutes.

CERTIFICATION

I hereby certify the foregoing to be a true and correct copy of a resolution duly adopted at the regular board meeting of the Metropolitan Park District of the Toledo Area held on January 18, 2023.

David D. Zenk
Executive Director

Approved as to Form:

(Amy Natyshak)
Attorney for the Board
January 18, 2023



**METROPARKS
TOLEDO**

Administrative Office

Board Brief

5100 West Central Avenue
Toledo, Ohio 43615-2100

419.407.9700
Fax **419.407.9785**

MetroparksToledo.com

Meeting Date: January 18, 2023
Agenda Item: Entity Beneficiary Resolution
Prepared By: Matt Cleland, Chief Financial Officer

DESCRIPTION:

Metroparks has been notified by American General Life Insurance Company of a death benefit. Decedent Mary Boyd has designated Metroparks as a 1.5% beneficiary with an approximate value of \$2,185.00. In order to claim the benefit, American General Life Insurance Company requires the Board of Park Commissioners to adopt an Entity Beneficiary Resolution.

RECOMMENDATION:

Adopt the Entity Beneficiary Resolution

METROPOLITAN PARK DISTRICT OF THE TOLEDO AREA

_____ offered and moved adoption of the following resolution:

RESOLUTION NO. 04-23

ENTITY BENEFICIARY RESOLUTION

WHEREAS, Metroparks Toledo has been notified of death benefit by American General Life Insurance Company, AND,

WHEREAS, Decedent Mary Boyd has designated Metroparks as a one and one half percent (1.5%) beneficiary in contract number UE238455, AND,

WHEREAS, American General Life Insurance Company requires adoption of an entity beneficiary resolution in order to claim the death benefit, NOW, THEREFORE,

BE IT RESOLVED, Dave Zenk, Executive Director, is authorized to claim death benefits on the annuity contract listed above on behalf of Metroparks Toledo, AND,

BE IT FURTHER RESOLVED, in the event of any change in the office or power of Dave Zenk, the Officer/Authorized Party will immediately certify those changes to American General Life Insurance in writing, AND,

BE IT FURTHER RESOLVED, to the extent allowed by law, American General Life Insurance Company is hereby released from any liability and shall be indemnified against any loss, liability or expense arising from honoring these resolutions.

_____ seconded the motion and upon _____ vote the resolution was declared duly adopted and recorded in the appendix to these minutes.

CERTIFICATION

I hereby certify the foregoing to be a true and correct copy of a resolution duly adopted at the regular board meeting of the Metropolitan Park District of the Toledo Area held on January 18, 2023.

David D. Zenk
Executive Director

Approved as to Form:
(Amy Natyshak)
Attorney for the Board
January 18, 2023



**METROPARKS
TOLEDO**
Administrative Office

Board Brief

5100 West Central Avenue
Toledo, Ohio 43615-2100

419.407.9700
Fax **419.407.9785**

MetroparksToledo.com

Meeting Date: January 18, 2023

Agenda Item: Authorization to Request Funding Through the Ohio Environmental Protection Agency

Prepared By: Allen Gallant, Director of Community Development

DESCRIPTION:

Ohio EPA's Recycling and Litter Prevention program supports communities, nonprofits, businesses and academic institutions that initiate or expand recycling programs, encourage sustainable practices, stimulate economic growth and support litter prevention efforts. As part of the Community and Litter Grants program local governments and nonprofits can receive funding to purchase equipment for the collection and processing of recyclables and construction and demolition debris. Organizations can also receive funding to implement litter collection events, outreach, and education.

Metroparks is planning to submit an application as part of the continuing effort to become a leader in sustainability. The Metroparks Toledo Green Team will be improving recycling programs in various parks and facilities throughout the district. Funds from this grant will enable us to purchase recycling bins and hardware, labels and signage, educational materials, and other equipment to collect various recyclable materials.

The maximum request is \$100,000.00 and a 25% match is required. The grant period is for 12 months: July 1, 2023 through June 30, 2024.

RECOMMENDATION:

Approve staff to submit applications for funding through the Ohio Environmental Protection Agency.

METROPOLITAN PARK DISTRICT OF THE TOLEDO AREA

_____ offered and moved adoption of the following resolution:

RESOLUTION NO. 05-23

**AUTHORIZATION TO REQUEST FUNDING THROUGH THE
OHIO ENVIRONMENTAL PROTECTION AGENCY**

WHEREAS, the Ohio Environmental Protection Agency provides a funding source to initiate or expand recycling programs and support litter prevention efforts, AND,

WHEREAS, Metroparks is seeking funding to purchase recycling bins and hardware, labels and signage, educational materials, and other equipment to collect various recyclable materials, AND,

WHEREAS, the standard match rate is twenty five percent (25%), AND,

WHEREAS, the Park District desires to seek an amount not to exceed \$100,000.00 toward project costs, NOW, THEREFORE,

BE IT RESOLVED, that the Board of Park Commissioners does approve the Park District to submit a grant application to the Ohio Environmental Protection Agency requesting an amount not to exceed \$100,000.00.

_____ seconded the motion and upon _____ vote the resolution was declared duly adopted and recorded in the appendix to these minutes.

CERTIFICATION

I hereby certify the foregoing to be a true and correct copy of a resolution duly adopted at the regular board meeting of the Metropolitan Park District of the Toledo Area held on January 18, 2023.

David D. Zenk
Executive Director

Approved as to Form:

(Amy Natyshak)
Attorney for the Board
January 18, 2023



**METROPARKS
TOLEDO**
Administrative Office

Board Brief

5100 West Central Avenue
Toledo, Ohio 43615-2100

419.407.9700
Fax **419.407.9785**

MetroparksToledo.com

Meeting Date: January 18, 2023

Agenda Item: Approval of First Amendment to Project Partner Agreement with The Nature Conservancy

Prepared By: Tim Schetter, Chief Natural Resources Officer

DESCRIPTION:

General Background

The Nature Conservancy (TNC) sponsors an In-Lieu Fee Stream and Wetland Mitigation Program in the State of Ohio (the "ILF Program") pursuant to an agreement between TNC, the U.S. Army Corps of Engineers and the Ohio EPA. This ILF Program provides compensatory mitigation for unavoidable adverse impacts to waters of the United States and State Waters that result from activities authorized under Section 404 of the Clean Water Act (33 U.S.C. 1344), the Ohio Revised Code (ORC Chapter 611 – Isolated Wetlands) and/or Ohio Administrative Code (OAC 3745-1) and/or Sections 9 or 10 of the Rivers and Harbors Act (33 U.S.C. §§ 401, 403).

Oak Openings Preserve Restoration Project Description

On July 22, 2020, the Board of Park Commissioners adopted Resolution 39-20, approving a project partner agreement with The Nature Conservancy to restore 16.1 acres of high-quality wetland and stream habitat at Oak Openings Preserve Metropark with funds from the ILF Program. During the project design phase, The Nature Conservancy identified opportunities to expand and enhance the initial project scope and deliverables to include 39.6 acres of habitat restoration.

The added scope of work addressed in this amendment includes a slight expansion in the size of the two original project locations as well as the addition of a third project location that will restore stream and wetland habitat along a former agricultural ditch draining into Al Creek, with the added benefits of expanding flood storage capacity and improving water quality flowing into Al Creek, a tributary of Swan Creek.

As per the original project agreement, Metroparks agrees to restrict activities (such as clearing, construction of buildings, etc.) that would negatively impact the restoration site's conservation values. Recreational uses that do not adversely affect the site's conservation values (such as walking trails) will continue to be allowed.

RECOMMENDATION:

Approve first amendment to project partner agreement with The Nature Conservancy.

Supplementary Materials Attached: Project location map and conceptual restoration plan

FIRST AMENDMENT TO PROJECT PARTNER AGREEMENT

This First Amendment to Project Partner Agreement (this "Amendment") is entered into by and between The Nature Conservancy, a District of Columbia nonprofit corporation (the "Conservancy"), and Toledo Metropolitan Park District ("Project Partner").

Recitals

A. The Conservancy and Project Partner entered into that certain Project Partner Agreement dated effective as of August 3, 2020 (the "Agreement"), pursuant to which the parties agreed to cooperate in the implementation of the Oak Openings Restoration In-Lieu Fee Mitigation Project (the "Project").

B. As part of the Project, the Project Partner committed to the Project approximately 16.1 acres of its land located in Lucas County, Ohio, as more particularly described in the Agreement (the "Original Property") and to provide perpetual protection of the Original Property.

C. The Project has expanded in size and the Project Partner is amenable to expanding the Original Property to include additional land constituting a total size of approximately 39.6 acres.

NOW THEREFORE, for and in consideration of the premises and for other good and valuable consideration, the receipt and sufficiency of which are hereby acknowledged, the Conservancy and Project Partner agree as follows:

1. The Property described in the Agreement is hereby amended to be that certain 39.6 acres of land, more or less, in Lucas County, Ohio, more particularly described on Attachment A attached hereto and incorporated herein by reference. Attachment A in the Agreement is hereby substituted and replaced with Attachment A attached hereto.
2. Except as amended by this Amendment, the Agreement is hereby ratified and confirmed in all respects. The Agreement as amended by this Amendment shall be read, taken and construed as one and the same instrument.
3. This Amendment may be executed in multiple counterparts, each of which shall constitute an original instrument, but all of which shall constitute one and the same Amendment. This Amendment shall become effective upon execution by both parties.

Signatures on following page.

THE NATURE CONSERVANCY

By: _____

Name: Bill Stanley _____

Title: Ohio State Director _____

Date: _____

Toledo Metropolitan Park District

By: _____

Name: _____



Title: Executive Director _____

Date: _____

Attachments:

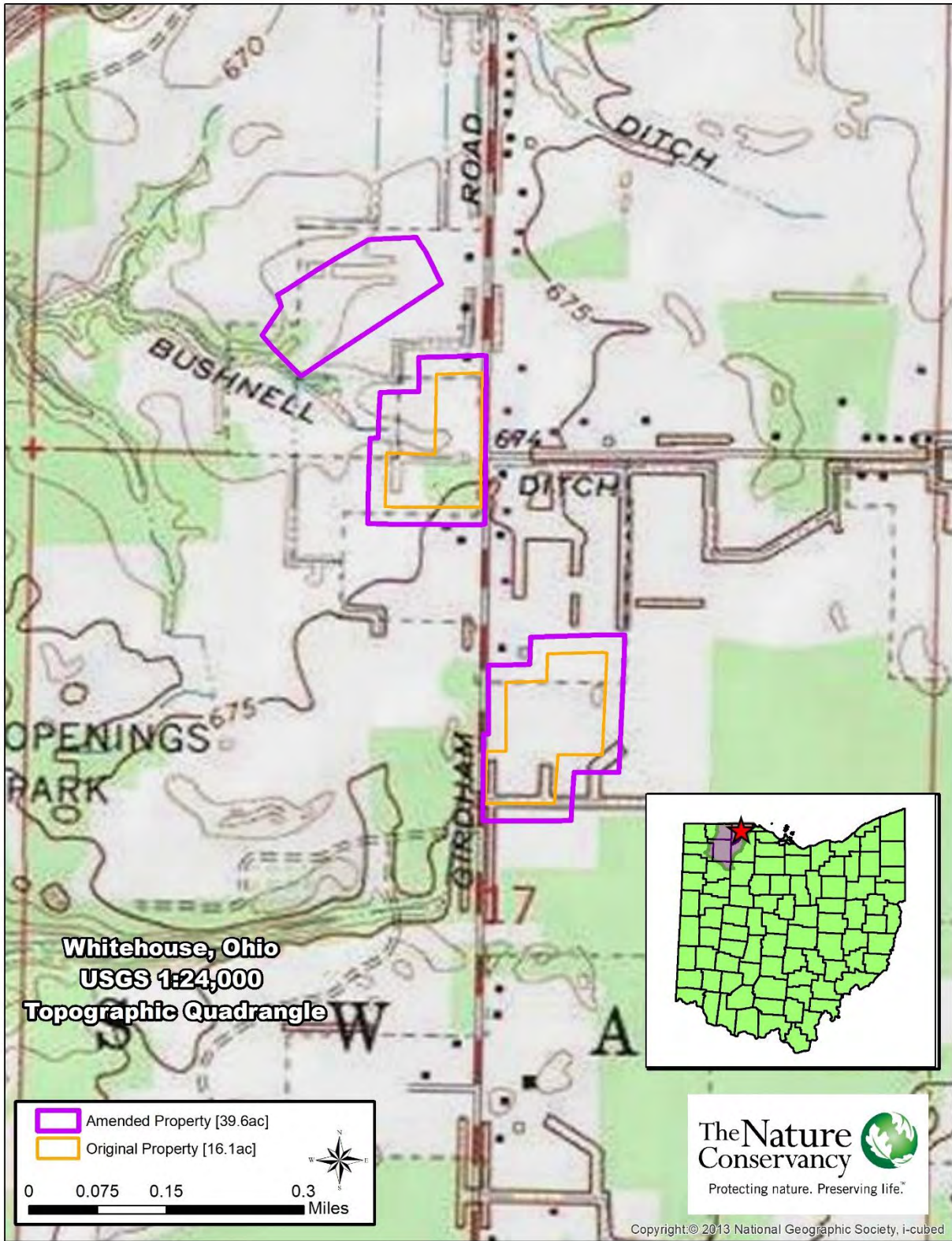
Attachment A – Map of Property



 Original Boundary (16.1 acres)
 Updated Boundary (39.6 acres)

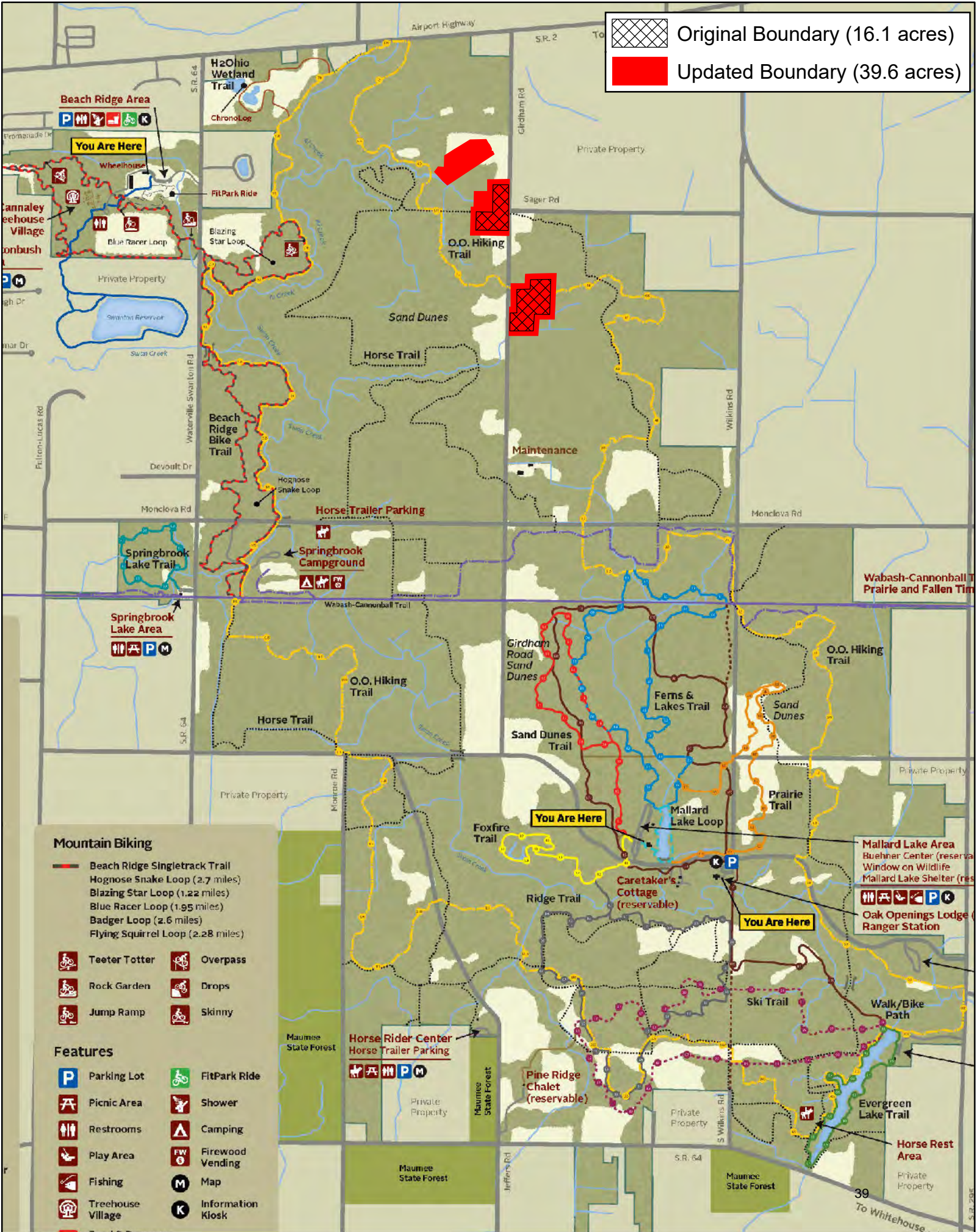

- Mountain Biking**
-  Beach Ridge Singletrack Trail
 -  Hognose Snake Loop (2.7 miles)
 -  Blazing Star Loop (1.22 miles)
 -  Blue Racer Loop (1.95 miles)
 -  Badger Loop (2.6 miles)
 -  Flying Squirrel Loop (2.28 miles)

-  Teeter Totter
-  Rock Garden
-  Jump Ramp
-  Overpass
-  Drops
-  Skinny

- Features**
-  Parking Lot
 -  Picnic Area
 -  Restrooms
 -  Play Area
 -  Fishing
 -  Treehouse Village
 -  FitPark Ride
 -  Shower
 -  Camping
 -  Firewood Vending
 -  Map
 -  Information Kiosk

Oak Openings Preserve

Amended Wetland Restoration Boundary



METROPOLITAN PARK DISTRICT OF THE TOLEDO AREA

_____ offered and moved adoption of the following resolution:

RESOLUTION NO. 06-23

**APPROVAL OF FIRST AMENDMENT TO PROJECT PARTNER AGREEMENT WITH
THE NATURE CONSERVANCY**

WHEREAS, The Nature Conservancy (TNC) sponsors an In-Lieu Fee Stream and Wetland Mitigation Program in the State of Ohio (the “ILF Program”) pursuant to an agreement between TNC, the U.S. Army Corps of Engineers and the Ohio EPA, AND,

WHEREAS, on July 22, 2020, the Metroparks Board of Park Commissioners adopted Resolution 39-20 approving a project partner agreement with TNC to restore high-quality wetlands and streams at Oak Openings Preserve Metropark (the Restoration Project) with funding from the ILF Program, AND,

WHEREAS, the original scope of the Restoration Project included 16.1 acres of parkland, leading to significant improvements in wildlife habitat and environmental quality, AND,

WHEREAS, the amended scope of the Restoration Project now includes 39.6 acres of parkland, leading to expanded improvements in wildlife habitat and environmental quality, AND,

WHEREAS, Metroparks agrees to restrict activities such as clearing and construction of buildings within the expanded Restoration Project area that would negatively impact the project area’s conservation values, NOW THEREFORE,

BE IT RESOLVED, that the Board of Park Commissioners does hereby approve the first amendment to the project partner agreement with The Nature Conservancy, subject to final approval by Metroparks staff and legal counsel of the final site restoration plan and site protection instrument to be recorded after final plan approval.

_____ seconded the motion and upon _____ vote the resolution was declared duly adopted and recorded in the appendix to these minutes.

CERTIFICATION

I hereby certify the foregoing to be a true and correct copy of a resolution duly adopted at the regular board meeting of the Metropolitan Park District of the Toledo Area held on January 18, 2023.

David D. Zenk
Executive Director

Approved as to Form:
(Amy Natyshak)
Attorney for the Board
January 18, 2023



**METROPARKS
TOLEDO**
Administrative Office

Board Brief

5100 West Central Avenue
Toledo, Ohio 43615-2100

419.407.9700
Fax **419.407.9785**

MetroparksToledo.com

Meeting Date: January 18, 2023

Agenda Item: Contract Approval, Blue Creek/Neis Ditch Stream
Restoration Design-Build Project

Prepared By: Zurijanne Carter, Deputy Chief Natural Resources
Officer

DESCRIPTION:

Sealed Letters of Interest (LOI's) for providing professional design-build services for the Blue Creek/Neis Ditch Stream Restoration Design-Build Project were received Friday, January 6, 2023 at 4:00 p.m. Four LOI responses were received. Biohabitats, Inc., of Cleveland, OH was found to be the overall best qualified firm to provide the required professional design-build services.

The Scope of Work consists of design, oversight and implementation of stream/ditch restoration to address benthic population and fish habitat beneficial use impairments in the Maumee Area Of Concern, increase flood capacity during high flow events, improve hydrology and water quality via sediment and nutrient load reduction through improved water retention, water treatment through plant assimilation of nutrients and settling of solids, and providing assistance to Metroparks with local, state and federal agency coordination and permitting, as necessary.

Funding for this project is made available through the US EPA Great Lakes Restoration Initiative fund. Total cost of professional engineering and construction is anticipated to be \$900,000.00.

RECOMMENDATION:

Approve a professional design-build contract with Biohabitats, Inc. not-to-exceed \$900,000.00.

Supplementary Materials Attached: Scoring Matrix

RFP Scoring BC and Neis Ditch 01092023

			Points	Haynes & Verdantas	Biohabitats	GEL-Gradel	Great Lakes & Mannik Smith
1	2-page signed cover letter						
2a	Contractor's understanding of the restoration Project		5	5	5	5	5
2b	Description of the approach to implement the required restoration practices within each Project Area. How the approach will meet and/or exceed the minimum Project requirements. Discussion of any additional observations, restoration practice alterations, cost-saving strategies, etc. A table should be provided that clearly defines the quantity of proposed restoration features (e.g., surface area and volume of flood storage capacity restored; linear feet of streambank restored / number of restoration features implemented; quantity and size of live stake, bare root, and containerized woody plantings.	Blue Creek stream restoration	10	10	10	10	10
		Neis Ditch flood expansion	10	9	9	10	9
		Neis Ditch stream restoration	10	10	10	10	10
2c	A description of water quality protection methods to be utilized during construction, as necessary.		3	3	3	3	0
2d	A list of equipment to be utilized.		3	3	3	3	3
3	3. A detailed budget should be prepared for the Project. The budget should relate to the quantity of work completed rather than a cost savings approach (i.e. rather than bidding \$20,000 less for the Project the Contractor should examine ways to create a higher quality conservation Project, for instance by increasing quantity of containerized plants over bare root stock). The Contractor may also include a budget narrative (no more than 1 page) if helpful in order to better support the budget.		3	3	2	3	2
4	Proposed Project schedule indicating all required tasks to successfully complete the project with major earthwork activities and site stabilization to be completed by September 15, 2017 and substantial completion of all Project activities by May 15, 2018. The Project schedule should include key milestones, deliverables, key coordination meetings and a proposed payment schedule.		3	3	3	3	3

RFP Scoring BC and Neis Ditch 01092023

			Points	Haynes & Verdantas	Biohabitats	GEL-Gradel	Great Lakes & Mannik Smith
5a	List and describe each entity, including proposed subcontractors, that are a part of the Contractor's Project team, including each entity's design-build experience and experience with projects similar in nature to the subject Project. If proposed subcontractors are not identified in the proposal, a rationale for how those subcontractors will be selected should be provided.		5	5	5	4	4
5b	A summary of 3 design-build stream restoration or other projects completed over the past five (5) years that have similarities and relevance to this proposed project and scope of services.	Project 1	10	10	9	5	5
		Project 2	10	9	9	7	10
		Project 3	10	8	10	5	2
5c	Identify all of the key Project team personnel, including key subcontractor personnel, who will be involved in the Project, including the experience, knowledge, technical expertise, certifications and licenses (including state of licensure), and resumes of key personnel.		5	5	5	5	5
6	Five (5) references, including contact information and a brief Project description. At least two of the references must be from among the 3 design-build stream and/or other restoration projects provided in Section 5(b) above.		1	1	1	1	1
7	A statement of the firm's primary office location. Designate the office location where the primary work, other than the project fieldwork, will be performed. Include anticipated type of work to be done at each office.		1	1	1	1	1
8	A written statement of the firm's familiarity with, and understanding of, any local, state and federal permits and regulations required to implement this project		5	4	5	5	5
9	A description of the firm's current workload. Include the availability of the firm to immediately commence this project upon receipt of a Notice to Proceed.		1	1	1	1	0
10	Value added		5	4	4	2	2
		TOTAL	100	94	95	83	77

METROPOLITAN PARK DISTRICT OF THE TOLEDO AREA

_____ offered and moved adoption of the following resolution:

RESOLUTION NO. 07-23

CONTRACT APPROVAL, BLUE CREEK/NEIS DITCH STREAM RESTORATION

WHEREAS, sealed proposals for bidding on the Blue Creek/Neis Ditch Stream Restoration Design-Build Project were received Friday, January 6, 2023 at 4:00 PM, AND,

WHEREAS, four (4) bids were received with Biohabitats, Inc., the overall best qualified firm at \$900,000., AND,

WHEREAS, the Scope of Work consists of design, oversight and implementation of stream/ditch restoration to address benthic population and fish habitat beneficial use impairments in the Maumee Area Of Concern, increase flood capacity during high flow events, improve hydrology and water quality via sediment and nutrient load reduction through improved water retention, water treatment through plant assimilation of nutrients and settling of solids, and providing assistance to Metroparks with local, state and federal agency coordination and permitting, as necessary, AND,

WHEREAS, the total cost of construction contracting is anticipated to be \$900,000.00, NOW, THEREFORE

BE IT RESOLVED, that the Board of Park Commissioners hereby approves an engineering construction contract with Biohabitats, Inc., for Blue Creek/Neis Ditch Stream Restoration Design-Build Project not-to-exceed \$900,000.00.

_____ seconded the motion and upon _____ vote the resolution was declared duly adopted and recorded in the appendix to these minutes.

CERTIFICATION

I hereby certify the foregoing to be a true and correct copy of a resolution duly adopted at the regular board meeting of the Metropolitan Park District of the Toledo Area held on January 18, 2023.

David D. Zenk
Executive Director

Approved as to Form:

(Amy Natyshak)
Attorney for the Board
January 18, 2023



**METROPARKS
TOLEDO**
Administrative Office

Board Brief

5100 West Central Avenue
Toledo, Ohio 43615-2100

419.407.9700
Fax **419.407.9785**

MetroparksToledo.com

Meeting Date: January 18, 2023

Agenda Item: Contract Approval, Audubon Islands State Nature Preserve Restoration Design-Build Project

Prepared By: Zurijanne Carter, Deputy Chief Natural Resources Officer

DESCRIPTION:

Sealed Letters of Interest (LOI's) for providing professional design-build services for the Audubon Islands State Nature Preserve Restoration Design-Build Project were received Friday, January 6, 2023 at 4:00 p.m. Two LOI responses were received. Mark Haynes Construction Inc., of Norwalk, Ohio was found to be the overall best qualified firm to provide the required professional design-build services.

The Scope of Work consists of design, oversight and implementation of bank stabilization techniques to address the degraded fish and wildlife populations, degradation of benthos, the loss of fish and wildlife habitat Beneficial Use Impairments (BUIs) in the Maumee Area of Concern through increased riverbank stability, increased habitat diversity and quality, and providing assistance to Metroparks with local, state and federal agency coordination and permitting, as necessary.

Funding for this project is made available through the US EPA Great Lakes Restoration Initiative fund. Total cost of professional engineering and construction is anticipated to be \$3,570,000.00.

RECOMMENDATION:

Approve a professional design-build contract with Mark Haynes Construction, Inc. not-to-exceed \$3,570,000.00.

Supplementary Materials Attached: Scoring Matrix

#	Description		Max Points	GLC	Scoring Notes	Haynes	Scoring Notes
1	2-page signed cover letter						
2a	Contractor's understanding of the restoration Project		5		5 scoring criteria met		5 scoring criteria met
2b	Description of the approach to implement the required restoration practices within each Project Area (30 total points; including 10 points for Ewing Island bank restoration, 10 points for Hunt Island bank restoration, and 10 points for Ewing Island cove restoration). How the approach will meet and/or exceed the minimum Project requirements. Discussion of any additional observations, restoration practice alterations, cost-saving strategies, etc. A table should be provided that clearly defines the quantity of proposed restoration features (e.g., surface area and volume of flood storage capacity restored; linear feet of streambank restored / number of restoration features implemented; quantity and size of live stake, bare root, and containerized woody plantings).	main island bank restoration	10		5 Scoring criteria only partially met. Proposal lacks key details on mobilization, staging, and approach to construction. Emphasizes designing to lake levels which aren't a driving factor at project location. By eliminating barrier islands, proposal omits key project deliverables.	10	Scoring criteria met. Proposal emphasizes outcomes over outputs. Provides detailed and methodical approach to mobilization, staging, and construction. Addresses existing and future habitat conditions (e.g. bank swallows, walleye). Detailed concept plan provided.
		Hunt island restoration	10		8 Scoring criteria largely met. Proposal demonstrates most deliverables achieved but omits barrier islands as above.	10	Scoring criteria met. Proposal demonstrates achievement of project deliverables (e.g. offshore reef habitat, shoreline plantings). Detailed approach provided as above.
		cove restoration	10		8 Scoring criteria largely met. Proposal demonstrates most deliverables achieved and provides innovative approach through engineered log jam but omits deep water habitat.	10	Scoring criteria met. Proposal demonstrates achievement of project deliverables with quantities, including deep water habitat along with detailed approach to achieving objectives.
2c	A description of water quality protection methods to be utilized during construction, as necessary.		3		3 scoring criteria met		3 scoring criteria met
2d	A list of equipment to be utilized.		3		3 scoring criteria met		3 scoring criteria met
3	3. A detailed budget should be prepared for the Project. The budget should relate to the quantity of work completed rather than a cost savings approach (i.e. rather than bidding \$20,000 less for the Project the Contractor should examine ways to create a higher quality conservation Project, for instance by increasing quantity of containerized plants over bare root stock). The Contractor may also include a budget narrative (no more than 1 page) if helpful in order to better support the budget.		3		2 Scoring criteria largely met but budget lacks some details and uses >20% of funds for engineering and design.		3 Scoring criteria met. Detailed project budget maximizes project deliverables with 90% of project budget focused on construction.
4	Proposed Project schedule indicating all required tasks to successfully complete the project with major earthwork activities and site stabilization to be completed by September 30, 2024 and substantial completion of all Project activities by September 30, 2025. The Project schedule should include key milestones, deliverables, key coordination meetings and a proposed payment schedule.		3		3 scoring criteria met		3 scoring criteria met
5a	List and describe each entity, including proposed subcontractors, that are a part of the Contractor's Project team, including each entity's design-build experience and experience with projects similar in nature to the subject Project. If proposed subcontractors are not identified in the proposal, a rationale for how those subcontractors will be selected should be provided.		5		5 scoring criteria met		5 scoring criteria met
5b	A summary of 3 design-build river restoration or other projects completed over the past five (5) years that have similarities and relevance to this proposed project and scope of services. Scoring emphasis shall be placed on projects completed within large riverine systems.	Project 1	10		10 Scoring criteria met. Exemplary project.		6 Scoring criteria only partially met. Project is comparable in scope and construction technique but does not directly address habitat.
		Project 2	10		5 Project falls short of scoring criteria. While similar techniques used, project does not involve habitat restoration.		8 Scoring criteria largely met. Project is similar in scope and approach but details on measured project deliverables were not included.
		Project 3	10		3 Project falls far short of scoring criteria. Not a comparable project (>300' feet of sheet pile installed). Lacks project details. Note: 4th submitted project not scored per scoring guidelines.		5 Project falls short of scoring criteria. While project achieves similar deliverables and implements relevant restoration techniques, it is much smaller in scope.
5c	Identify all of the key Project team personnel, including key subcontractor personnel, who will be involved in the Project, including the experience, knowledge, technical expertise, certifications and licenses (including state of licensure), and resumes of key personnel.		5		5 scoring criteria met		5 scoring criteria met
6	Five (5) references, including contact information and a brief Project description. At least two of the references must be from among the 3 design-build stream and/or other restoration projects provided in Section 5(b) above.		1		1 scoring criteria met		1 scoring criteria met
7	A statement of the firm's primary office location. Designate the office location where the primary work, other than the project fieldwork, will be performed. Include anticipated type of work to be done at each office.		1		1 scoring criteria met		1 scoring criteria met
8	A written statement of the firm's familiarity with, and understanding of, any local, state and federal permits and regulations required to implement this project		5		5 Scoring criteria met. Proposal provides detailed understanding and approach to permitting process.		4 Scoring criteria largely met but proposal is lacking in details.
9	A description of the firm's current workload. Include the availability of the firm to immediately commence this project upon receipt of a Notice to Proceed.		1		1 scoring criteria met		1 scoring criteria met
10	Value added. How would the firm prioritize and/or utilize additional funding if made available, to improve the project.		5		5 Scoring criteria met. Noted value added on outreach and diversity inclusion was especially of interest.		5 Scoring criteria met. Value added was clearly demonstrated with budget-saving approach to site access and integration of materials needed for access into overall project deliverables.
		TOTAL	100	78			88

METROPOLITAN PARK DISTRICT OF THE TOLEDO AREA

_____ offered and moved adoption of the following resolution:

RESOLUTION NO. 08-23

CONTRACT APPROVAL, AUDUBON ISLANDS STATE NATURE PRESERVE RESTORATION

WHEREAS, sealed proposals for bidding on the Audubon Islands State Nature Preserve Design-Build Project in Oak Openings Preserve Metropark were received Friday, January 6, 2023 at 4:00 PM, AND,

WHEREAS, two (2) bids were received with Mark Haynes Construction Inc., the overall best qualified firm at \$3,570,000.00, AND,

WHEREAS, the Scope of Work consists of design, oversight and implementation of bank stabilization techniques to address the degraded fish and wildlife populations, degradation of benthos, the loss of fish and wildlife habitat Beneficial Use Impairments (BUIs) in the Maumee Area of Concern through increased riverbank stability, increased habitat diversity and quality, and providing assistance to Metroparks with local, state and federal agency coordination and permitting, as necessary, AND,

WHEREAS, the total cost of construction and engineering contracting is anticipated to be \$3,570,000.00, NOW, THEREFORE

BE IT RESOLVED, that the Board of Park Commissioners hereby approves a construction contract with Mark Haynes Construction Inc., not-to-exceed \$3,570,000.00.

_____ seconded the motion and upon _____ vote the resolution was declared duly adopted and recorded in the appendix to these minutes.

CERTIFICATION

I hereby certify the foregoing to be a true and correct copy of a resolution duly adopted at the regular board meeting of the Metropolitan Park District of the Toledo Area held on January 18, 2023.

David D. Zenk
Executive Director

Approved as to Form:

(Amy Natyshak)
Attorney for the Board
January 18, 2023



**METROPARKS
TOLEDO**
Administrative Office

Board Brief

5100 West Central Avenue
Toledo, Ohio 43615-2100

419.407.9700
Fax **419.407.9785**

MetroparksToledo.com

Meeting Date: January 18, 2023

Agenda Item: Contract Approval, Pearson Metropark Tennis Court Improvements & Pickleball Conversion

Prepared By: Doug Parrish, P.E., Project Engineer

DESCRIPTION:

Sealed proposals for bidding on the Pearson Metropark Tennis Court Improvements & Pickleball Conversion, 761 S. Lallendorf Rd., Oregon, OH 43616 were received Friday, January 6, 2023 at 10:00 AM. One (1) bid was received with Laser Striping and Sport Surfacing being the apparent lowest and best bidder at \$82,900.00.

The Scope of Work consists of resealing and striping of the existing tennis courts with reconfiguration to provide two tennis courts and four pickleball courts. General construction involves sport court surfacing, color sealing, striping, crack filling, net installations, new fencing and other associated work.

The total cost of construction contracting is anticipated to be \$91,190.00 which includes the construction contract (\$82,900.00) plus a ten percent (10%) construction contingency (\$8,290.00).

RECOMMENDATION:

Approve a construction contract with **Laser Striping and Sport Surfacing** for Pearson Metropark Tennis Court Improvements & Pickleball Conversion not-to-exceed \$91,190.00. (Contract amount + ten percent (10%) contingency).

Supplementary Materials Attached: *Bid Tabulation & Final Plan*

**Tennis Court Improvements & Pickball Conversion,
Pearson Metropark, 761 S Lallendorf Rd, Oregon, OH 43616**
 Bid Opening: Friday, January 6, 2023 at 10:00 a.m., local time
BID TABULATION

Certified Encouraging Diversity, Growth and Equity (EDGE) by State of Ohio
 Certified Minority Business Enterprise (MBE) by State of Ohio, Section 129.03C
 Certified Women's Business Enterprise (WBE) by State of Ohio
 Certified Small Disadvantaged Business (SDB) by SBA
 Veteran Owned

COMPANY NAME	DISCIPLINE	PHONE	EMAIL	CONTACT NAME	ADDRESS	Total Base Bid Amount	EDGE	MBE	WBE	SDB	Vet
Laser Striping and Sport Surfacing	General Contractor	(313) 779-8415	mike_sealmi@live.com	Mike Laser	42040 Koppernick Bldg D, Ste. 43, Canton MI 48187	\$82,900.00					
The Courtsmiths	General Contractor	(419) 531-6292	mike@courtsmiths.com	Mike Smith	4694 W. Bancroft St, Toledo, OH 43615	No Bid					
Premier Sport-Tennis Court Construction/Resurfacing	General Contractor	(508) 340-9713	ryan@premiersealcoatingma.com	Ryan	340 Quail Ridge Ct., Waterford Twp, MI	No Bid					
Total Tennis, Inc.	General Contractor	(614) 488-5004	zach.boyt@totaltennisinc.com	Zach Boyt	321 W. Bigelow Ave., Plain City, OH 43064	No Bid					
All American Track & Tennis	General Contractor	(800) 667-9619	info@allamericantrack.com		8105 Leavitt Rd, Amherst, OH 44001	No Bid					
ENGINEER'S ESTIMATE						\$89,000.00					
ENGINEER'S ESTIMATE + 10%						\$97,900.00					



EXISTING PLAN

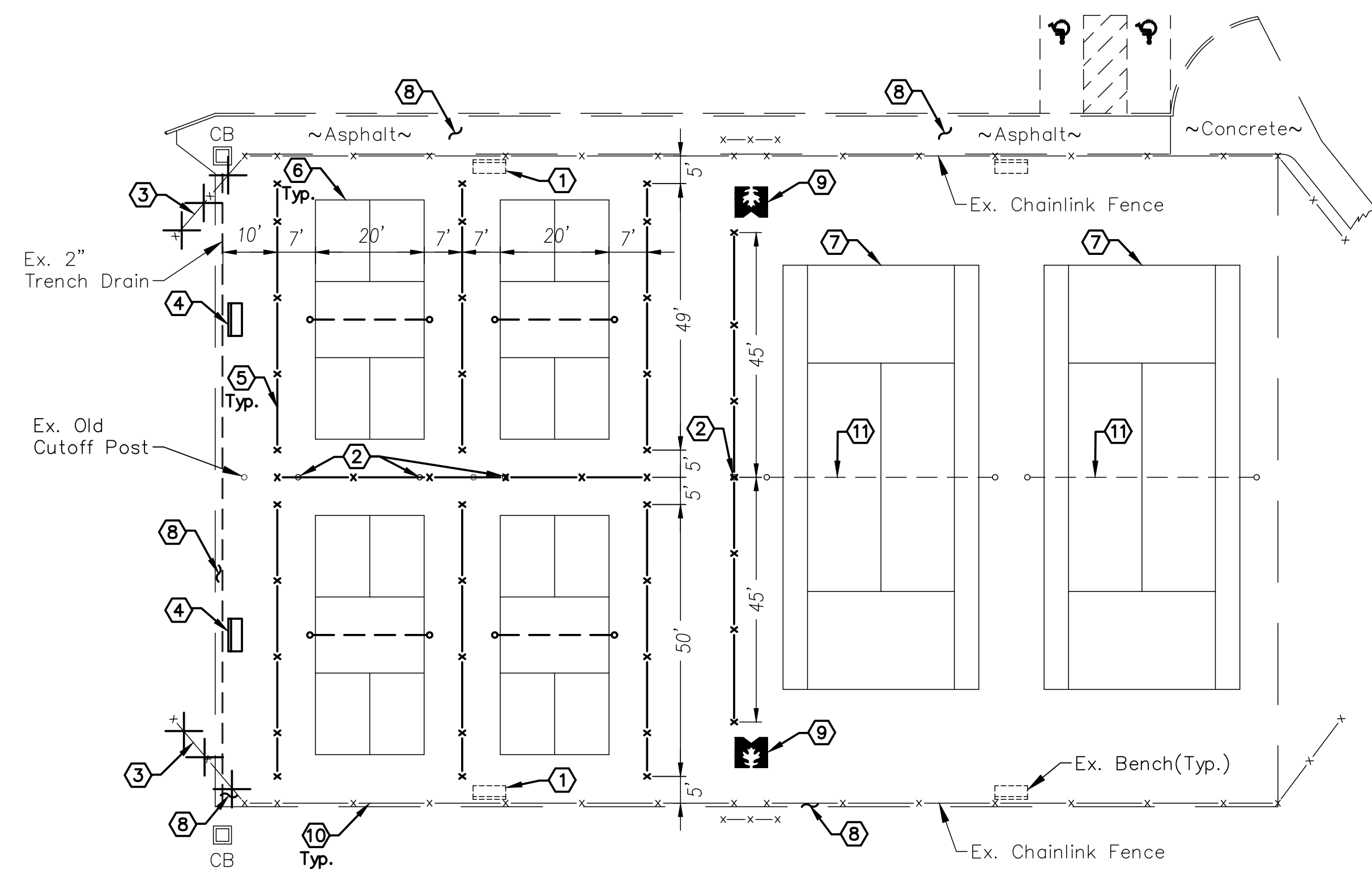

PROPOSED PLAN



KEYED NOTES:

- ① RELOCATE EX. BENCH (BY METROPARKS)
- ② REMOVE EXISTING POST (4 EACH - CUTOFF FLUSH AT BASE)
- ③ REMOVE FENCE (40 FT.± TOTAL)
- ④ RELOCATED BENCH LOCATION
- ⑤ PROPOSED 48" HIGH FENCE (SEE DETAIL)
- ⑥ PROPOSED PICKLEBALL COURT (4 TOTAL-SEE DETAIL)
- ⑦ STANDARD TENNIS COURT (LOCATION TO REMAIN THE SAME)
- ⑧ SEAL WITH ASPHALT EMULSION SEALER (1 COAT, SEALMASTER MASTERSEAL OR EQUAL)
- ⑨ METROPARK LOGO, TEXTURED WHITE ACRYLIC (72"x67")
- ⑩ COURT NUMBER SIGN
- ⑪ REPLACE EXISTING TENNIS COURT NETS (2 TOTAL)

ENLARGED PICKLEBALL COURT (N.T.S)

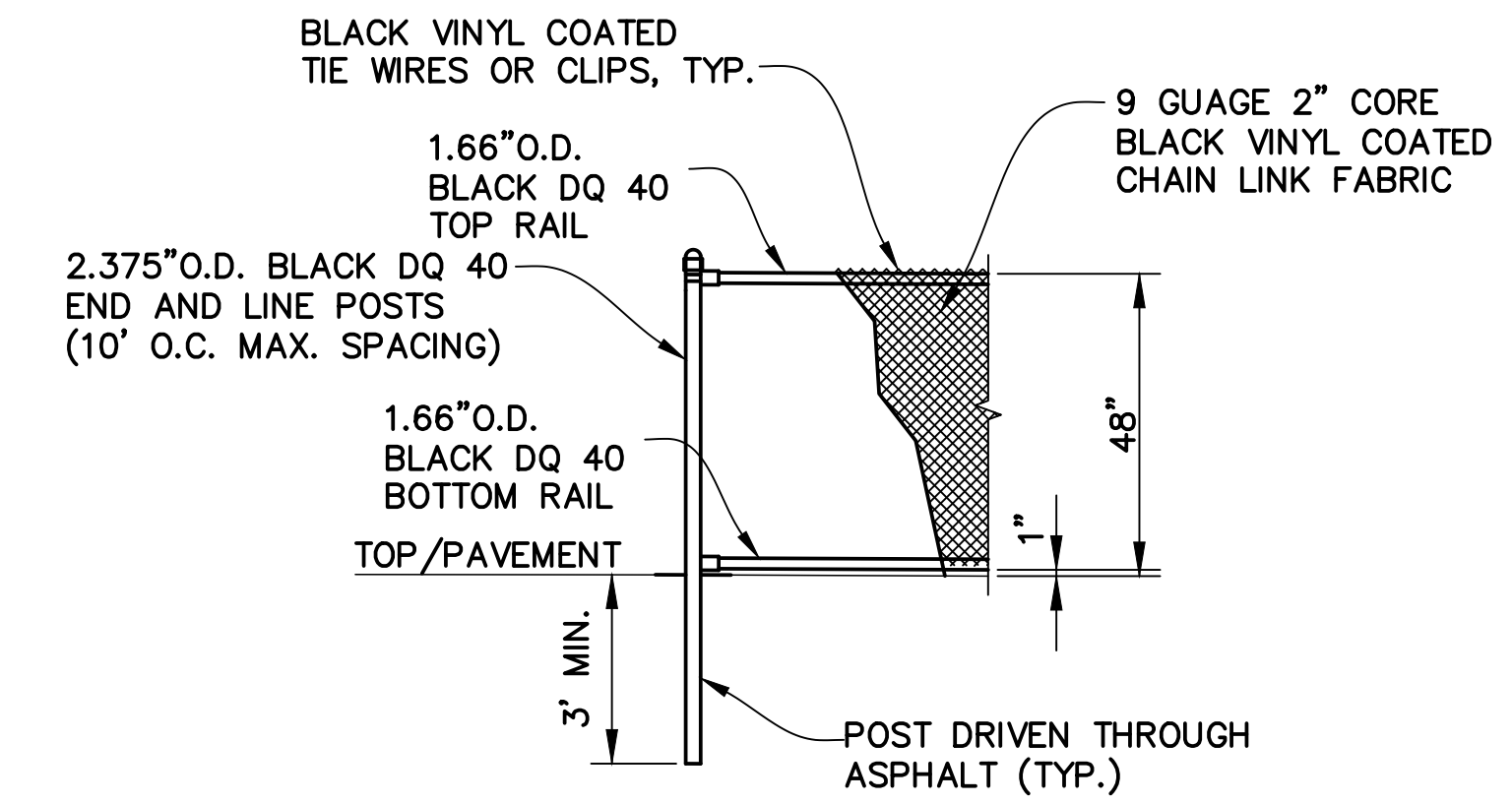
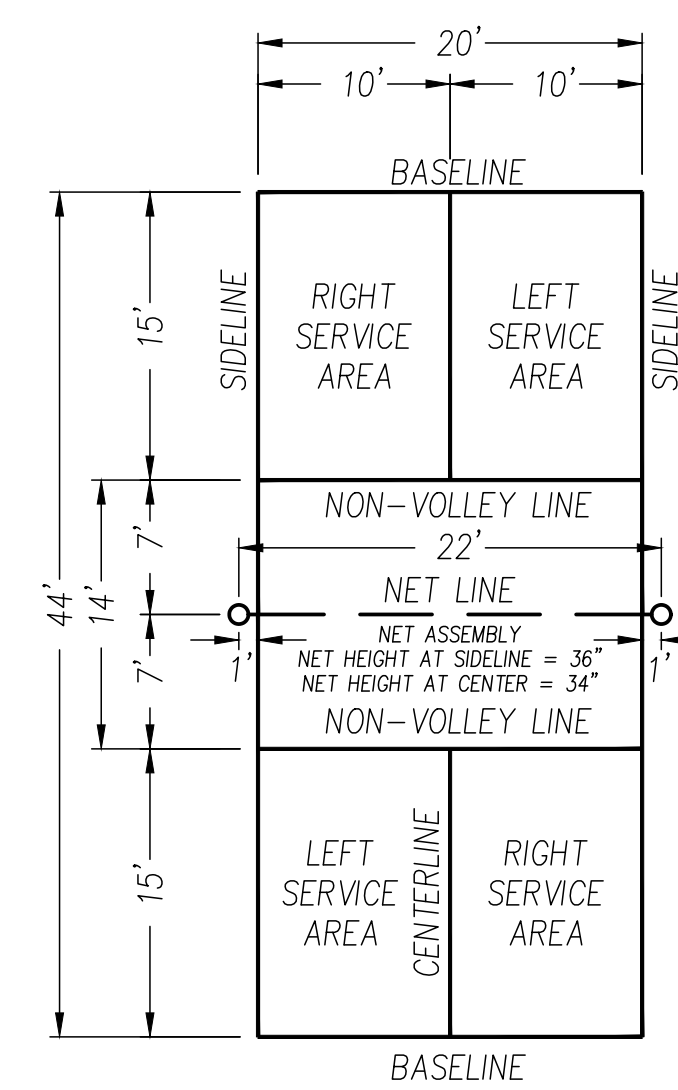

TYPICAL 48" HIGH FENCE (N.T.S)

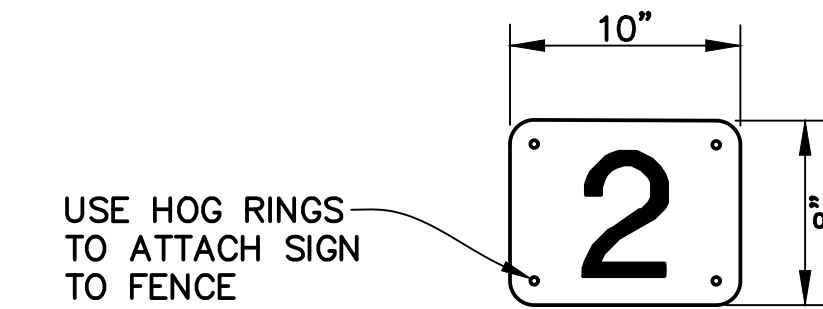

TYPICAL COURT NUMBER SIGN (N.T.S)

EXISTING COURT SURFACE PREPARATION

ALL AREAS TO RECEIVE NEW COATINGS SHALL BE CLEANED AND PRESSURE WASHED TO MAXIMIZE BONDING OF NEW SURFACE COATINGS. EXISTING LOW AREAS AND SURFACE CRACKS SHALL BE FILLED WITH ASBA APPROVED PATCHING MATERIAL.

CRACK REPAIRS

LARGER CRACKS SHALL BE FILLED UTILIZING RITEWAY CRACK REPAIR SYSTEM FOLLOWING THE MANUFACTURER'S RECOMMENDATIONS.

COURT NOTES

COURT MEASUREMENTS SHALL BE MADE TO THE OUTSIDE OF THE COURT LINES. COURT LINES SHALL BE TWO(2) INCHES WIDE AND PAINT SHALL BE TEXTURED WHITE ACRYLIC. COURTS SHALL BE SURFACED WITH A THREE(3) COAT ACRYLIC TENNIS SYSTEM APPLIED TO ENTIRE EXISTING SURFACED AREA. THIS WILL CONSIST OF ONE APPLICATION OF ACRYLIC SURFACER WITH SAND AND TWO APPLICATIONS OF COLOR ACRYLIC WITH SAND.

- COURT PLAY AREA SURFACE COLOR: BLUE
- COURT OVERRUN AREA SURFACE COLOR: GREEN

INSTALL FOUR(4) SETS OF DOUGLAS PREMIER PICKLEBALL POSTS, FOUR(4) CENTER TIE DOWN ANCHORS AND FOUR(4) PN-30 PICKLEBALL NETS WITH CENTER STRAPS. REPLACE TWO(2) EXISTING TENNIS NETS WITH DOUGLAS TN-36DMT NETS. ALL POSTS AND NETS SHALL BE INSTALLED IN ACCORDANCE WITH MANUFACTURER RECOMMENDATIONS.

SIGN NOTES

COURT NUMBER SIGNS SHALL BE MADE FROM A MINIMUM OF 0.04 GAUGE ALUMINUM BLANK WITH ROUNDED CORNERS. COORDINATE WITH OWNER ON COLOR OF SIGN. COLOR SHALL BE UV PRINTED ON ALUMINUM BLANKS. SIGNS SHALL BE NUMBERED SEQUENTIALLY.

MAINTAINING TRAFFIC AND ACCESS

PROPOSED WORK AREAS SHALL BE VISIBLY BARRICADED, SIGNED AND BLOCKED OFF PRIOR TO THE START OF CONSTRUCTION AND SHALL BE PROPERLY MAINTAINED. BARRICADES AND SIGNING SHALL REMAIN IN PLACE ONLY AS LONG AS THEY ARE NEEDED AND SHALL BE IMMEDIATELY REMOVED THEREAFTER.

PARKING AND ACCESS TO ADJACENT PARK FACILITIES SHALL BE MAINTAINED FOR VISITORS, STAFF AND DAILY PARK OPERATIONS AS DIRECTED BY THE OWNER.

DESIGNED	12/2/22	PRELIMINARY REVIEW	
DJP	12/9/22	FINAL PLANS	
CHECKED			
JZ			
1.	REV.	DATE	DESCRIPTION
2.			
3.			

Schedule of Payables
For the month ended December 31, 2022

GL Account Number	Project Number	GL Account Description	Payment Date	Check Number	Amount	Vendor Name	PO Number	Invoice Line Description
Various	Salaries and Benefits				\$ 1,081,621.93			
100.0000.441300	ENC FACILITY RENTAL FEES		12/23/2022	67382	\$ 150.00	90002 (Other Refunds)	2022003278	CS_Facility rental refund_Regina Mosley_#99578_\$150.00
100.0000.441401	TREEHOUSE VILLAGE OVERNIGHT RENTAL FEE		12/9/2022	67350	\$ 175.00	90002 (Other Refunds)	2022003044	CS_Facility Rental Refund_Julie Weidner_#99102_\$306.06
			12/9/2022	67351	\$ 200.00	90002 (Other Refunds)	2022003043	CS_Facility rental refund_Julie Weidner_#99103_\$335.50
100.0000.441999	RENTAL DEPOSIT/CANCELLATION FEE - DW		12/2/2022	67324	\$ 100.00	90002 (Other Refunds)	2022002887	CS_Facility rental refund_Jennifer Newton-Smith_#98409_\$100.00
			12/2/2022	67325	\$ 100.00	90002 (Other Refunds)	2022002884	CS_Facility rental refund_Pat Groves_#98416_\$100.00
			12/2/2022	67326	\$ 100.00	90002 (Other Refunds)	2022002882	CS_Facility Rental Refund_Michelle Crisp_#98631_\$100.00
			12/2/2022	67327	\$ 100.00	90002 (Other Refunds)	2022002891	CS_Facility rental refund_Kelly Bandfield_#98399_\$100.00
			12/2/2022	67328	\$ 100.00	90002 (Other Refunds)	2022002890	CS_Facility rental refund_Kristen Chambers_#98403_\$100.00
			12/2/2022	67329	\$ 100.00	90002 (Other Refunds)	2022002881	CS_Facility rental refund_Brittani Martin_#98645_\$100.00
			12/2/2022	67330	\$ 100.00	90002 (Other Refunds)	2022002889	CS_Facility rental refund_Bill Davis_#98404_\$100.00
			12/2/2022	67331	\$ 100.00	90002 (Other Refunds)	2022002888	CS_Facility rental refund_Marissa Ketelhut_#98407_\$100.00
			12/2/2022	67332	\$ 100.00	90002 (Other Refunds)	2022002885	CS_Facility rental refund_Antonio Sofo_#98411_\$100.00
			12/2/2022	67333	\$ 100.00	90002 (Other Refunds)	2022002886	CS_Facility rental refund_Ying Ning_#98410_\$100.00
			12/2/2022	67334	\$ 20.00	90002 (Other Refunds)	2022002892	CS_Facility Rental Refund_David Bayly_#98603_\$20.00
			12/2/2022	67335	\$ 100.00	90002 (Other Refunds)	2022002883	CS_Facility Rental Refund_Matt Cook_#98627_\$100.00
			12/9/2022	67350	\$ 100.00	90002 (Other Refunds)	2022003044	CS_Facility Rental Refund_Julie Weidner_#99102_\$306.06
			12/9/2022	67351	\$ 100.00	90002 (Other Refunds)	2022003043	CS_Facility rental refund_Julie Weidner_#99103_\$335.50
			12/9/2022	67352	\$ 100.00	90002 (Other Refunds)	2022003083	CS_Facility Rental Refund_Julie Iler_#99300_\$100.00
100.0000.490700	SALES TAX REVENUE		12/9/2022	67350	\$ 13.56	90002 (Other Refunds)	2022003044	CS_Facility Rental Refund_Julie Weidner_#99102_\$306.06
			12/9/2022	67351	\$ 15.50	90002 (Other Refunds)	2022003043	CS_Facility rental refund_Julie Weidner_#99103_\$335.50
100.0000.490800	Lodging Tax Revenue		12/9/2022	67350	\$ 17.50	90002 (Other Refunds)	2022003044	CS_Facility Rental Refund_Julie Weidner_#99102_\$306.06
			12/9/2022	67351	\$ 20.00	90002 (Other Refunds)	2022003043	CS_Facility rental refund_Julie Weidner_#99103_\$335.50
100.0000.491400	REIMBURSEMENTS		12/2/2022	6021179	\$ 13.96	5653 (PGN Consulting)	2022000096	DW_Employee reimbursement to Metroparks
			12/16/2022	6021269	\$ 20.73	5653 (PGN Consulting)	2022000096	DW_Employee reimbursement to Metroparks
			12/16/2022	6021269	\$ 3.98	5653 (PGN Consulting)	2022000096	DW_Employee reimbursement to Metroparks
			12/16/2022	6021269	\$ 1.27	5653 (PGN Consulting)	2022000096	DW_Employee reimbursement to Metroparks
			12/16/2022	6021277	\$ 141.86	01227 (Superior Uniform Sales, Inc.)	2022000096	DW_Employee reimbursement to Metroparks
			12/23/2022	6021294	\$ 48.63	08615 (AIA Corporation)	2022000096	DW_Employee reimbursement to Metroparks
			12/23/2022	6021294	\$ 15.43	08615 (AIA Corporation)	2022000096	DW_Employee reimbursement to Metroparks
			12/23/2022	6021294	\$ 31.36	08615 (AIA Corporation)	2022000096	DW_Employee reimbursement to Metroparks
			12/31/2022	CC:65351	\$ 1.55	07600 (Fifth Third Credit Card)	2022000096	DW_Employee reimbursement to Metroparks
			12/31/2022	CC:65351	\$ 5.94	07600 (Fifth Third Credit Card)	2022000096	DW_Employee reimbursement to Metroparks
			12/31/2022	CC:65351	\$ 6.09	07600 (Fifth Third Credit Card)	2022000096	DW_Employee reimbursement to Metroparks
100.1000.520800	MILEAGE - OD		12/16/2022	6021291	\$ 15.69	08167 (Jill Molnar)	2022000103	OD_Mileage
100.1000.550100	CONFERENCES/ TRAINING - OD		12/31/2022	CC:65351	\$ 129.00	07600 (Fifth Third Credit Card)	2022003262	OD_Jill's Nov 2022 cc ref: 2022000133
100.1000.550200	MEMBERSHIP DUES - OD		12/23/2022	67376	\$ 495.00	07093 (Destination Toledo, Inc.)	2022002876	Destination Toledo Membership Dues
			12/31/2022	CC:65351	\$ 1,625.00	07600 (Fifth Third Credit Card)	2022003262	OD_Jill's Nov 2022 cc ref: 2022000133
100.1000.557100	UNIFORMS - OD		12/16/2022	6021254	\$ 38.00	08615 (AIA Corporation)	2022001285	Uniforms - Jill M
100.1000.580800	OTHER NON-OP EXP - OD		12/16/2022	6021266	\$ 70.00	4775 (Nick Amrhein)	2022002765	Leadership Photos
100.1003.550100	CONFERENCES/ TRAINING - DIV		12/31/2022	CC:65351	\$ 39.98	07600 (Fifth Third Credit Card)	2022003225	DIV_Felica's Nov 2022 cc ref: 2022000133
100.1003.551900	MISC CONTRACT SVCS - DIV		12/23/2022	6021326	\$ 1,500.00	5653 (PGN Consulting)	2022003204	DIV_Development of blueprint for supplier
100.2000.520300	HEALTH INSURANCE - DW		12/9/2022	6021216	\$ 122,908.40	02544 (Lucas County Treasurer)	2022000113	DW_Health insurance
100.2000.551100	LEGAL SERVICES - DW		12/2/2022	6021176	\$ 550.00	5476 (Marshall & Melhorn, LLC)	2022002380	DW_Legal services
			12/2/2022	6021176	\$ 3,612.50	5476 (Marshall & Melhorn, LLC)	2022002380	DW_Legal services
			12/2/2022	6021176	\$ 1,170.00	5476 (Marshall & Melhorn, LLC)	2022002380	DW_Legal services
			12/2/2022	6021176	\$ 3,530.00	5476 (Marshall & Melhorn, LLC)	2022002380	DW_Legal services
			12/2/2022	6021176	\$ 1,805.00	5476 (Marshall & Melhorn, LLC)	2022002380	DW_Legal services
			12/2/2022	6021176	\$ 4,180.00	5476 (Marshall & Melhorn, LLC)	2022002380	DW_Legal services
			12/2/2022	6021176	\$ 385.00	5476 (Marshall & Melhorn, LLC)	2022002380	DW_Legal services
			12/2/2022	6021176	\$ 1,640.00	5476 (Marshall & Melhorn, LLC)	2022002380	DW_Legal services
			12/2/2022	6021176	\$ 1,351.00	5476 (Marshall & Melhorn, LLC)	2022002380	DW_Legal services
			12/2/2022	6021176	\$ 775.50	5476 (Marshall & Melhorn, LLC)	2022002786	DW_Legal services
			12/2/2022	6021176	\$ 147.50	5476 (Marshall & Melhorn, LLC)	2022002786	DW_Legal services
			12/9/2022	6021227	\$ 875.00	01156 (Spengler Nathanson PLL)	2022000131	DW_Legal services
			12/23/2022	6021319	\$ 3,437.50	5476 (Marshall & Melhorn, LLC)	2022002786	DW_Legal services

		12/23/2022	6021319	\$	7,762.25	5476 (Marshall & Melhorn, LLC)	2022002786	DW_Legal services
		12/23/2022	6021319	\$	2,492.50	5476 (Marshall & Melhorn, LLC)	2022002786	DW_Legal services
		12/23/2022	6021319	\$	370.00	5476 (Marshall & Melhorn, LLC)	2022002786	DW_Legal services
		12/23/2022	6021319	\$	962.50	5476 (Marshall & Melhorn, LLC)	2022002786	DW_Legal services
		12/23/2022	6021319	\$	687.50	5476 (Marshall & Melhorn, LLC)	2022002786	DW_Legal services
		12/23/2022	6021319	\$	1,045.00	5476 (Marshall & Melhorn, LLC)	2022002786	DW_Legal services
		12/23/2022	6021319	\$	495.00	5476 (Marshall & Melhorn, LLC)	2022002786	DW_Legal services
		12/23/2022	6021319	\$	1,567.50	5476 (Marshall & Melhorn, LLC)	2022002786	DW_Legal services
		12/23/2022	6021319	\$	2,055.00	5476 (Marshall & Melhorn, LLC)	2022002786	DW_Legal services
		12/23/2022	6021332	\$	1,875.00	01156 (Spengler Nathanson PLL)	2022000131	DW_Legal services
100.2000.551700	BANKING SERVICES - DW	12/31/2022	796	\$	25.00	04332 (Fifth Third Processing Solutions)	2022000137	Fin_Fees-stop payments/wire transfer/service chg
		12/31/2022	9918	\$	2,794.71	06623 (Signature Bank, NA)	2022000137	Fin_Fees-stop payments/wire transfer/service chg
100.2000.551900	MISC CONTRACT SVCS - DW	12/16/2022	6021271	\$	2,500.00	5275 (Real Good Ventures, LLC)	2022002060	DW_Consulting services for Senior Team Training
		12/31/2022	CC:65351	\$	2,995.00	07600 (Fifth Third Credit Card)	2022003267	NRC_Tim G's Nov 2022 cc ref: 2022000133
100.2000.556200	SALES TAX REMITTANCE - DW	12/30/2022	9914	\$	1,156.48	03646 (Ohio Dept. of Taxation)	2022000051	Sales Tax
100.2000.556300	LODGING TAX REMITTANCE - DW	12/20/2022	67371	\$	1,481.50	05150 (Lucas County Treasurer)	2022000144	Hotel/Lodging Tax
100.2001.520800	MILEAGE - FIN	12/2/2022	6021156	\$	153.50	5714 (Rachael Champion)	2022000102	Fin_mileage
100.2001.530100	Small equipment, furniture and fixtures - FIN	12/30/2022	9907	\$	81.49	04427 (Amazon Prime)	2022003210	DW_Amazon Dec 2022 paym ref: 2022000723
100.2001.531100	OFFICE SUPPLIES - FIN	12/31/2022	CC:65351	\$	49.98	07600 (Fifth Third Credit Card)	2022003230	FIN_Matt C's Nov 2022 cc ref: 2022000133
100.2001.551900	MISC CONTRACT SVCS - FIN	12/9/2022	6021225	\$	3,000.00	07142 (Software Solutions, Inc.)	2022001916	FIN_On-site consulting and support for existing finance software
100.2001.557100	UNIFORMS - FIN	12/2/2022	6021179	\$	88.90	5653 (PGN Consulting)	2022000110	FIN_Uniform allowance-Comptroller
		12/9/2022	6021195	\$	88.00	08615 (AIA Corporation)	2022000112	FIN_Uniform allowance-Acctg Specialist
		12/16/2022	6021254	\$	58.95	08615 (AIA Corporation)	2022000107	Fin_Uniform allowance-K Shindel
100.3001.531100	OFFICE SUPPLIES - ES	12/30/2022	9907	\$	174.24	04427 (Amazon Prime)	2022003210	DW_Amazon Dec 2022 paym ref: 2022000723
100.3001.531200	POSTAGE - ES	12/23/2022	67384	\$	800.00	5208 (Quadient Leasing USA, Inc.)	2022003046	AD_Postage for Meter
100.3001.550100	CONFERENCES/ TRAINING - ES	12/16/2022	67370	\$	2,334.90	06933 (WHEELING PARK COMMISSION)	2022002649	AS_Supervisor Training Oglebay
		12/31/2022	CC:65351	\$	258.47	07600 (Fifth Third Credit Card)	2022003260	Training
		12/31/2022	CC:65351	\$	55.00	07600 (Fifth Third Credit Card)	2022003223	HR Training
100.3001.551900	MISC CONTRACT SVCS - ES	12/2/2022	67319	\$	400.00	5087 (Central Behavioral Healthcare, Inc.)	2022002563	AD_Ranger Evaluation
		12/2/2022	67319	\$	400.00	5087 (Central Behavioral Healthcare, Inc.)	2022002851	AD_Ranger Evaluation
		12/2/2022	67319	\$	400.00	5087 (Central Behavioral Healthcare, Inc.)	2022002852	AD_Ranger Evaluation
		12/23/2022	67373	\$	400.00	5087 (Central Behavioral Healthcare, Inc.)	2022002932	AD_Ranger Evaluation
		12/31/2022	CC:65351	\$	62.50	07600 (Fifth Third Credit Card)	2022003223	Annual CDL checks
100.3001.551908	Background Checks - ES	12/9/2022	6021204	\$	554.75	05122 (Corporate Intelligence Consultants, Inc.)	2022002856	AD_Background Checks
100.3001.553100	LEGAL NOTICES - ES	12/2/2022	67340	\$	87.50	5153 (Welch Publishing Co.)	2022000165	AD_Job Postings
		12/16/2022	67365	\$	37.50	00508 (The Mirror)	2022000165	AD_Job Postings
		12/16/2022	67365	\$	45.00	00508 (The Mirror)	2022000165	AD_Job Postings
		12/16/2022	67366	\$	88.75	01331 (The Toledo Journal)	2022000165	AD_Job Postings
		12/16/2022	67369	\$	125.00	5153 (Welch Publishing Co.)	2022000165	AD_Job Postings
		12/9/2022	6021197	\$	53.20	4933 (AIM Media Midwest Operating, LLC)	2022000165	AD_Job Postings
		12/23/2022	6021321	\$	1,900.00	08981 (Monster Worldwide, Inc.)	2022003058	AD_Job Posting
		12/23/2022	6021336	\$	80.00	04162 (The Sojourner's Truth)	2022000165	AD_Job Postings
		12/31/2022	CC:65351	\$	(1,815.00)	07600 (Fifth Third Credit Card)	2022003223	Refund - Job Posting Site
		12/31/2022	CC:65351	\$	50.00	07600 (Fifth Third Credit Card)	2022003223	Job Posting
100.3001.557100	UNIFORMS - ES	12/16/2022	6021254	\$	89.95	08615 (AIA Corporation)	2022000003	AD_Uniforms
		12/16/2022	6021254	\$	102.95	08615 (AIA Corporation)	2022000003	AD_Uniforms
100.3001.580200	CONTINGENCY - ES	12/31/2022	CC:65351	\$	80.76	07600 (Fifth Third Credit Card)	2022003223	Bootcamp
100.3002.530100	SM EQUIP/ FURN/ FIXTURES - VOL	12/31/2022	CC:65351	\$	52.50	07600 (Fifth Third Credit Card)	2022003265	VOL SRVS_Shannon's Nov 2022 cc ref: 2022000133
100.3002.530900	OTHER OP MTRLS & SUPPLIES - VOL	12/31/2022	CC:65351	\$	39.00	07600 (Fifth Third Credit Card)	2022003241	MKTG_Val's Nov 2022 cc ref: 2022000133
		12/31/2022	CC:65351	\$	28.40	07600 (Fifth Third Credit Card)	2022003265	VOL SRVS_Shannon's Nov 2022 cc ref: 2022000133
100.3002.550100	CONFERENCES/ TRAINING - VOL	12/31/2022	CC:65351	\$	230.00	07600 (Fifth Third Credit Card)	2022003264	PRG_Shannon's Nov 2022 cc ref: 2022000133
		12/31/2022	CC:65351	\$	1,058.00	07600 (Fifth Third Credit Card)	2022003265	VOL SRVS_Shannon's Nov 2022 cc ref: 2022000133
		12/31/2022	CC:65351	\$	160.00	07600 (Fifth Third Credit Card)	2022003264	PRG_Shannon's Nov 2022 cc ref: 2022000133
100.3002.557100	UNIFORMS - VOL	12/2/2022	6021179	\$	100.00	5653 (PGN Consulting)	2022000559	VOL_Uniform for Meredith
		12/2/2022	6021179	\$	29.48	5653 (PGN Consulting)	2022002917	Vols_coverage shortage on MB uni

100.3003.531600	COMPUTER SUPPLIES - IS	12/2/2022	6021178	\$	392.00	03760 (New Era Technology)	2022002690	IS_Supplies
100.3003.540700	TELEPHONE - IS	12/9/2022	9876	\$	268.38	05663 (AT&T)	2022000129	IS_Telephone usage
		12/16/2022	9886	\$	1,439.06	05663 (AT&T)	2022002930	IS_AT&T 831-000-9192-365 Dec invoice
		12/16/2022	9893	\$	597.75	05764 (Verizon Wireless)	2022002927	IS_Verizon 542093698-00001Dec invoice
		12/16/2022	9893	\$	472.83	05764 (Verizon Wireless)	2022002929	IS_Verizon 542093698-00002Dec invoice
		12/23/2022	9899	\$	168.10	07092 (Brightspeed)	2022002942	IS_Brightspeed Dec invoice
		12/23/2022	9900	\$	313.78	07027 (Buckeye Broadband)	2022002933	IS_Buckeye 8158 10 600 0002467 Dec invoice
		12/23/2022	9900	\$	303.20	07027 (Buckeye Broadband)	2022002934	IS_Buckeye 8158 10 600 0000479 Dec invoice
		12/23/2022	9903	\$	9,167.13	04012 (Telesystem)	2022003051	IS_Telesystem utility invoice
		12/23/2022	9906	\$	1,460.30	05790 (Windstream)	2022002923	IS_Windstream Dec invoice
		12/30/2022	9910	\$	75.95	05663 (AT&T)	2022002946	IS_AT&T 151989732 Dec invoice
		12/30/2022	9912	\$	205.19	07240 (Frontier)	2022002939	IS_Frontier Dec invoice
		12/30/2022	9916	\$	6,642.76	06329 (Verizon Wireless)	2022000129	IS_Telephone usage
		12/30/2022	9916	\$	107.64	06329 (Verizon Wireless)	2023000001	IS_KS_Telephone usage
100.3003.550100	CONFERENCES/ TRAINING - IS	12/31/2022	CC:65351	\$	16.95	07600 (Fifth Third Credit Card)	2022003236	IS_Heather's Nov 2022 cc ref: 2022000133
100.3003.551900	MISC CONTRACT SVCS - IS	12/2/2022	6021178	\$	120.00	03760 (New Era Technology)	2022002690	IS_S&H
		12/2/2022	6021178	\$	48.61	03760 (New Era Technology)	2022002812	IS_S&H
		12/2/2022	6021178	\$	278.04	03760 (New Era Technology)	2022002690	IS_Care package
		12/16/2022	6021268	\$	240.20	07367 (Perry ProTech Inc.)	2022002078	IS_Print/copy services
		12/23/2022	6021325	\$	145.09	07367 (Perry ProTech Inc.)	2022002780	IS_Copy/print services
		12/31/2022	CC:65351	\$	264.00	07600 (Fifth Third Credit Card)	2022003236	IS_Heather's Nov 2022 cc ref: 2022000133
100.3003.552100	COMPUTER/ TECHNOLOGY - IS	12/2/2022	6021178	\$	2,295.00	03760 (New Era Technology)	2022000132	IS_Total DR monthly subscription
		12/16/2022	6021284	\$	19,089.84	4608 (Vermont Systems, Inc.)	2022002864	IS_RecTrac renewal
		12/23/2022	6021322	\$	2,295.00	03760 (New Era Technology)	2022001132	IS_Total DR monthly subscription
		12/31/2022	CC:65351	\$	357.78	07600 (Fifth Third Credit Card)	2022003236	IS_Heather's Nov 2022 cc ref: 2022000133
		12/31/2022	CC:65352	\$	350.00	07002 (Volgistics, Inc.)	2022000222	IS_Volgistics
		12/31/2022	CC:65352	\$	350.00	07002 (Volgistics, Inc.)	2022000232	IS_Volgistics
100.3003.552300	PHONE MAINTENANCE - IS	12/16/2022	6021273	\$	2,045.18	5453 (RingCentral Inc.)	2022000026	IS_ACO phone services
100.3003.573400	TECHNOLOGICAL EQUIPMENT - IS	12/2/2022	6021178	\$	850.00	03760 (New Era Technology)	2022002690	IS_HP Laserjet Pro M479 M479fdn Laser Multifunction
		12/2/2022	6021178	\$	229.11	03760 (New Era Technology)	2022002812	IS_HP Officejet Pro 8025e Inkjet Multifunction Printer
		12/2/2022	6021178	\$	76.49	03760 (New Era Technology)	2022002812	IS_HP ink
		12/31/2022	CC:65351	\$	507.60	07600 (Fifth Third Credit Card)	2022003236	IS_Heather's Nov 2022 cc ref: 2022000133
100.3004.550100	CONFERENCES/ TRAINING - CS	12/31/2022	CC:65351	\$	160.00	07600 (Fifth Third Credit Card)	2022003264	PRG_Shannon's Nov 2022 cc ref: 2022000133
100.3004.557100	UNIFORMS - CS	12/2/2022	6021179	\$	100.00	5653 (PGN Consulting)	2022002097	Jerri Fink Uniform
100.4000.520800	MILEAGE - MKTG	12/2/2022	6021157	\$	183.75	01837 (Scott Carpenter)	2022000161	MKTG_mileage for Department
		12/9/2022	6021248	\$	35.63	04448 (Valerie Juhasz)	2022000161	MKTG_mileage for Department
100.4000.530900	OTHER OP MTRLS & SUPPLIES - MKTG	12/16/2022	67361	\$	196.00	03392 (H.O.T. Graphic & Services, Inc.)	2022003008	MKTG_notecards
		12/31/2022	CC:65351	\$	29.00	07600 (Fifth Third Credit Card)	2022003241	MKTG_Val's Nov 2022 cc ref: 2022000133
		12/31/2022	CC:65351	\$	20.00	07600 (Fifth Third Credit Card)	2022003241	MKTG_Val's Nov 2022 cc ref: 2022000133
100.4000.531100	OFFICE SUPPLIES - MKTG	12/23/2022	67386	\$	1,474.40	5704 (Stealth Mode Three LLC)	2022002836	MKTG_table cloths for event tables
		12/31/2022	CC:65351	\$	53.55	07600 (Fifth Third Credit Card)	2022003241	MKTG_Val's Nov 2022 cc ref: 2022000133
100.4000.531400	PAPER & PRINTING - MKTG	12/16/2022	6021255	\$	338.16	08089 (Arrow Print & Copy LLC)	2022002878	MKTG_printing of scavenger hunt sheets/flyer
100.4000.550100	CONFERENCES/ TRAINING - MKTG	12/31/2022	CC:65351	\$	340.29	07600 (Fifth Third Credit Card)	2022003249	MKTG_Scott's Nov 2022 cc ref: 2022000133
100.4000.550200	MEMBERSHIP DUES - MKTG	12/9/2022	6021229	\$	415.00	06137 (Toledo Regional Chamber of Commerce)	2022002911	MKTG_membership dues for Toledo Chamber of Commerce
100.4000.551900	MISC CONTRACT SVCS - MKTG	12/9/2022	67355	\$	4,036.50	01691 (The Toledo Blade Company)	2022002868	MKTG_ad for in Toledo Blade and eBlade for Field of Histories event
		12/23/2022	67375	\$	7.35	5684 (Cumulus Media LLC-Toledo)	2022002510	MKTG_radio advertising for Metroparks
		12/23/2022	67375	\$	714.00	5684 (Cumulus Media LLC-Toledo)	2022002510	MKTG_radio advertising for Metroparks
		12/23/2022	67375	\$	315.00	5684 (Cumulus Media LLC-Toledo)	2022002510	MKTG_radio advertising for Metroparks
		12/23/2022	67375	\$	10.40	5684 (Cumulus Media LLC-Toledo)	2022002510	MKTG_radio advertising for Metroparks
		12/23/2022	67375	\$	210.00	5684 (Cumulus Media LLC-Toledo)	2022002510	MKTG_radio advertising for Metroparks
		12/23/2022	67375	\$	10.50	5684 (Cumulus Media LLC-Toledo)	2022002510	MKTG_radio advertising for Metroparks
		12/23/2022	67375	\$	10.50	5684 (Cumulus Media LLC-Toledo)	2022002510	MKTG_radio advertising for Metroparks
		12/23/2022	67375	\$	2,520.00	5684 (Cumulus Media LLC-Toledo)	2022002510	MKTG_radio advertising for Metroparks
		12/23/2022	67375	\$	102.00	5684 (Cumulus Media LLC-Toledo)	2022002510	MKTG_radio advertising for Metroparks
		12/23/2022	67375	\$	10.50	5684 (Cumulus Media LLC-Toledo)	2022002510	MKTG_radio advertising for Metroparks
		12/23/2022	67375	\$	945.00	5684 (Cumulus Media LLC-Toledo)	2022002510	MKTG_radio advertising for Metroparks
		12/23/2022	67375	\$	105.00	5684 (Cumulus Media LLC-Toledo)	2022002510	MKTG_radio advertising for Metroparks
		12/23/2022	67375	\$	10.50	5684 (Cumulus Media LLC-Toledo)	2022002510	MKTG_radio advertising for Metroparks
		12/23/2022	67375	\$	5.25	5684 (Cumulus Media LLC-Toledo)	2022002510	MKTG_radio advertising for Metroparks
		12/23/2022	67377	\$	225.60	5238 (DexYP)	2022002656	MKTG_yellow pages directory
		12/23/2022	67377	\$	225.60	5238 (DexYP)	2022002656	MKTG_yellow pages directory
		12/23/2022	67389	\$	750.00	03357 (WGTE Public Media)	2022003216	MKTG_sponsor for WGTE color contest

		12/2/2022	6021164	\$	1,600.00	4700 (Daniel Woodcock)	2022001929	MKTG_social media posts
		12/9/2022	6021206	\$	1,500.00	4700 (Daniel Woodcock)	2022002867	MKTG_social media posts for 3 months
		12/9/2022	6021217	\$	105.00	04369 (Media Library Ohio LLC)	2022000588	MKTG_Monitoring Fee
		12/9/2022	6021231	\$	500.00	08583 (Toledo.com Inc.)	2022000444	MKTG_banner ads for homepage exposure of events, ect.
		12/23/2022	6021324	\$	1,450.00	03932 (One Day Sign, Inc.)	2022003062	MKTG_recycle decals for new containers district wide
		12/23/2022	6021334	\$	320.00	04391 (Tamie Spears)	2022000952	MKTG_freelance graphic design help with projects
		12/23/2022	6021334	\$	340.00	04391 (Tamie Spears)	2022003277	MKTG_freelance design work
		12/23/2022	6021337	\$	250.00	4740 (Toledo GROWS, Inc.)	2022002816	MKTG_ad for seed swap for Toledo Grows
100.4000.551905	Videos - MKTG	12/23/2022	6021329	\$	800.00	5066 (Running Wild Media)	2022002866	MKTG_Video production and Photography for Metroparks
100.4000.551906	Photography - MKTG	12/23/2022	6021305	\$	1,950.00	5718 (Dougiefresh Photo LLC)	2022000124	MKTG_various freelance photography services
100.4000.551907	Marketing Services - MKTG	12/16/2022	6021258	\$	2,820.88	08584 (Everwild, LLC)	2022000951	MKTG_hosting fees and other design work
100.4000.553200	ADVERTISING & PUBLICATIONS - MKTG	12/16/2022	67367	\$	5,000.00	5256 (Thunder Tech, Inc.)	2022000216	MKTG_advertising placement
		12/23/2022	67387	\$	1,010.41	5256 (Thunder Tech, Inc.)	2022000216	MKTG_advertising placement
		12/23/2022	67387	\$	4,352.28	5256 (Thunder Tech, Inc.)	2022000216	MKTG_advertising placement
100.4000.553500	PR & EDN SIGNS - MKTG	12/31/2022	CC:65351	\$	46.00	07600 (Fifth Third Credit Card)	2022003241	MKTG_Val's Nov 2022 cc ref: 2022000133
100.4000.557100	UNIFORMS - MKTG	12/9/2022	6021221	\$	189.98	5653 (PGN Consulting)	2022000147	MKTG_uniform allowance for department
		12/9/2022	6021221	\$	112.49	5653 (PGN Consulting)	2022000147	MKTG_uniform allowance for department
		12/16/2022	6021254	\$	238.99	08615 (AIA Corporation)	2022000147	MKTG_uniform allowance for department
		12/16/2022	6021254	\$	206.97	08615 (AIA Corporation)	2022000147	MKTG_uniform allowance for department
		12/16/2022	6021254	\$	64.00	08615 (AIA Corporation)	2022000147	MKTG_uniform allowance for department
		12/23/2022	6021294	\$	208.98	08615 (AIA Corporation)	2022000147	MKTG_uniform allowance for department
100.4006.520800	MILEAGE - SPV	12/16/2022	6021292	\$	75.00	08264 (Ruth Griffin)	2022000644	SPV_mileage - Events
100.4006.530800	MTRLS & SUPPLIES FOR SPV/HOLIDAYS - SPV	12/16/2022	9892	\$	750.00	04571 (Lowe's)	2022002482	SPE_Snowplace supplies
		12/30/2022	9907	\$	656.36	04427 (Amazon Prime)	2022002772	SPV_Shipman decorations - Holidays
		12/23/2022	67383	\$	50.00	03269 (Paul Jomantas)	2022002843	SPV_musicians - Holidays
		12/9/2022	6021212	\$	4,000.00	05542 (Jacob Coolman)	2022002508	SPV_carriage rides - Holidays at the Manor House
		12/23/2022	6021298	\$	2,965.00	01864 (Century Equipment)	2022002459	SPV_carts - Holidays
		12/23/2022	6021302	\$	35.00	03899 (Culligan of Northwest Ohio)	2022002724	SPV_misc needs - Holidays
		12/23/2022	6021302	\$	182.00	03899 (Culligan of Northwest Ohio)	2022002748	SPV_water and cooler - Holidays
		12/23/2022	6021333	\$	4,900.38	06140 (Sunbelt Rentals)	2022002507	SPV_light towers - Holidays
		12/23/2022	6021333	\$	7.80	06140 (Sunbelt Rentals)	2022002507	SPV_light towers - Holidays
		12/23/2022	6021333	\$	175.95	06140 (Sunbelt Rentals)	2022002724	SPV_misc needs - Holidays
		12/31/2022	CC:65351	\$	69.84	07600 (Fifth Third Credit Card)	2022002724	SPV_misc needs - Holidays
		12/31/2022	CC:65351	\$	2,139.05	07600 (Fifth Third Credit Card)	2022002724	SPV_misc needs - Holidays
		12/31/2022	CC:65351	\$	1,564.56	07600 (Fifth Third Credit Card)	2022002802	SPV_Climbing Tree - Holidays
		12/31/2022	CC:65351	\$	62.00	07600 (Fifth Third Credit Card)	2022003241	MKTG_Val's Nov 2022 cc ref: 2022000133
		12/31/2022	CC:65351	\$	1,939.00	07600 (Fifth Third Credit Card)	2022003241	MKTG_Val's Nov 2022 cc ref: 2022000133
		12/31/2022	CC:65353	\$	615.56	04561 (Gordon Food Service)	2022002840	SPV_snacks - Holidays
		12/31/2022	CC:65354	\$	160.93	04427 (Amazon Prime)	2022002819	SPV_smores sticks - Holiday's
100.4006.531100	OFFICE SUPPLIES - SPV	12/31/2022	CC:65354	\$	34.37	04427 (Amazon Prime)	2022002754	SPV_ink - office supplies
		12/31/2022	CC:65354	\$	41.09	04427 (Amazon Prime)	2022002795	SPV_ink - printer
100.4006.532300	EXHIBIT SUPPLIES - SPV	12/16/2022	9892	\$	1,400.00	04571 (Lowe's)	2022002495	SPV_plywood - Snowplace
		12/23/2022	67386	\$	2,400.00	5704 (Stealth Mode Three LLC)	2022002834	SPV_tablecloths - Event use
		12/9/2022	6021218	\$	490.95	07689 (Minuteman Press)	2022002030	SPV_flyers - BugFest
		12/31/2022	CC:65351	\$	22.99	07600 (Fifth Third Credit Card)	2022003261	SPV_Ruth's Nov 2022 cc ref: 2022000133
		12/31/2022	CC:65351	\$	442.50	07600 (Fifth Third Credit Card)	2022003241	MKTG_Val's Nov 2022 cc ref: 2022000133
100.4006.551900	MISC CONTRACT SVCS - SPV	12/16/2022	67359	\$	2,500.00	5407 (Creadio, LLC)	2022003220	SPV_video production - Ride the Lights
		12/9/2022	6021201	\$	255.00	05234 (Co-Man)	2022002853	SPV_portapots - Nickel Dash
		12/16/2022	6021252	\$	1,600.00	07265 (ACE DIVERSIFIED SERVICES, LLC.)	2022002156	SPV_Barriers for Glow-tacular
		12/16/2022	6021256	\$	70.00	05234 (Co-Man)	2022002396	SPV_portapot - Howard Phase II Opening
		12/23/2022	6021300	\$	70.00	05234 (Co-Man)	2022002270	SPV_portapot - Westwinds
		12/23/2022	6021300	\$	395.00	05234 (Co-Man)	2022002308	SPV_GC portable restrooms for concert 9.30
		12/23/2022	6021300	\$	255.00	05234 (Co-Man)	2022002311	SPV_SW portable restrooms for 5k race 9.17
		12/31/2022	CC:65351	\$	809.63	07600 (Fifth Third Credit Card)	2022003261	SPV_Ruth's Nov 2022 cc ref: 2022000133
		12/31/2022	CC:65351	\$	46.00	07600 (Fifth Third Credit Card)	2022003241	MKTG_Val's Nov 2022 cc ref: 2022000133
		12/31/2022	CC:65351	\$	1,925.00	07600 (Fifth Third Credit Card)	2022003265	VOL SRVS_Shannon's Nov 2022 cc ref: 2022000133
		12/31/2022	CC:65359	\$	1,800.35	4877 (Jupmode)	2022002790	SVP_hoodie - Trail Series
100.5000.530900	OTHER OP MTRLS & SUPPLIES - CC	12/31/2022	CC:65351	\$	269.80	07600 (Fifth Third Credit Card)	2022003252	CC_Brad H's Nov 2022 cc ref: 2022000133
100.5000.551900	MISC CONTRACT SVCS - CC	12/2/2022	6021188	\$	952.31	06601 (United Rentals (North America), Inc.)	2022001907	OPS_CC_Annual JLG Lift Inspection and Service
		12/23/2022	6021294	\$	132.00	08615 (AIA Corporation)	2022000877	PC_Construction Crew Hi-Viz Shirts for Glass City
100.5000.558400	FLEET VEHICLE REPAIR - CC	12/31/2022	CC:65351	\$	300.00	07600 (Fifth Third Credit Card)	2022003251	P&C_Brad H's Nov 2022 cc ref: 2022000133
100.5001.520800	MILEAGE - PC	12/9/2022	6021240	\$	143.50	5538 (Jennifer Van Horn)	2022000146	PC_Mileage 2021

			12/16/2022	6021290	\$	108.63	5538 (Jennifer Van Horn)		2022000146	PC_Mileage 2021
100.5001.531100	OFFICE SUPPLIES - PC		12/31/2022	CC:65351	\$	40.00	07600 (Fifth Third Credit Card)		2022003239	P&C_Jon's Nov 2022 cc ref: 2022000133
100.5001.550100	CONFERENCES/ TRAINING - PC		12/31/2022	CC:65351	\$	731.35	07600 (Fifth Third Credit Card)		2022003246	P&C_Jen's Nov 2022 cc ref: 2022000133
			12/31/2022	CC:65351	\$	15.00	07600 (Fifth Third Credit Card)		2022003239	P&C_Jon's Nov 2022 cc ref: 2022000133
			12/31/2022	CC:65351	\$	370.00	07600 (Fifth Third Credit Card)		2022003251	P&C_Brad H's Nov 2022 cc ref: 2022000133
100.5001.551900	MISC CONTRACT SVCS - PC		12/2/2022	6021189	\$	937.50	5674 (Verdantas LLC)		2022002282	PC_Toledo Landfill Solar Preliminary Design
			12/23/2022	6021339	\$	3,227.50	5674 (Verdantas LLC)		2022002282	PC_Toledo Landfill Solar Preliminary Design
100.5001.553200	ADVERTISING & PUBLICATIONS - PC		12/9/2022	67355	\$	810.92	01691 (The Toledo Blade Company)		2022002763	PC_Legal Advertisement - BC Electric Service Renovation
100.5001.557100	Uniforms - PC		12/9/2022	6021195	\$	211.98	08615 (AIA Corporation)		2022000151	PC_Uniforms
			12/16/2022	6021254	\$	288.94	08615 (AIA Corporation)		2022000151	PC_Uniforms
			12/16/2022	6021254	\$	56.00	08615 (AIA Corporation)		2022000151	PC_Uniforms
			12/23/2022	6021294	\$	99.98	08615 (AIA Corporation)		2022000151	PC_Uniforms
			12/23/2022	6021294	\$	200.00	08615 (AIA Corporation)		2022002741	PC_Winter Uniform/Logowear for J. Hyde
			12/23/2022	6021294	\$	200.00	08615 (AIA Corporation)		2022002742	PC_Winter Uniform/Logowear for J. Van Horn
100.5002.530900	OTHER OP MTRLS & SUPPLIES - SAF		12/31/2022	CC:65351	\$	245.88	07600 (Fifth Third Credit Card)		2022003253	OPS_Brad N. Nov 2022 cc ref: 2022000133
100.5003.551900	MISC CONTRACT SVCS_CR		12/9/2022	6021196	\$	546.93	07543 (Buehrer Group Architecture & Engineering, Inc.)		2022001607	OPS_BC_Electrical Engineering Services for Overhead Line Relocation
100.5003.552800	BUILDINGS - PAIR/MAINT/RENO_BUILDINGS_CR		12/23/2022	67379	\$	1,937.20	5647 (Grayhawk Greenhouse Supply LLC)		2022002086	OPS_TBG_Reskinning of Greenhouse Bays 5 and 7
			12/23/2022	67379	\$	3,500.00	5647 (Grayhawk Greenhouse Supply LLC)		2022002086	OPS_TBG_Reskinning of Greenhouse Bays 5 and 7
			12/23/2022	6021309	\$	18,658.52	5413 (Five Star Maintenance & Construction Inc.)		2022001346	OPS_OO_Services to Prep and Paint Lodge Exterior
100.5003.552900	STRUCTURES_NON-BLDGS - PAIR/MAINT/RENO - CR		12/2/2022	6021163	\$	16,887.00	4631 (Coleman Systems, Inc.)		2022002648	PC_TBG_Heat Exchanger Replacement for Five Greenhouse Units
20043305			12/2/2022	6021171	\$	493.92	4887 (Green Earth Transportation)		2022002773	PC_SI_Base Stone for Lock #3 Concrete Pad
			12/2/2022	6021172	\$	308.00	04772 (Klumm Bros LTD)		2022001560	OPS_Roll-Off Dumpster For International Park Sidewalk Repair
			12/9/2022	6021232	\$	2,443.86	06601 (United Rentals (North America), Inc.)		2022002847	PC_WW_Lift Rental
20043305			12/23/2022	6021314	\$	1,219.47	4887 (Green Earth Transportation)		2022002773	PC_SI_Base Stone for Lock #3 Concrete Pad
			12/23/2022	6021330	\$	7,411.21	00987 (Sandman Sales Yard, LLC)		2022001701	OPS_SI_Ledge Stone for Lock Restoration
210405510			12/31/2022	CC:65351	\$	2,551.62	07600 (Fifth Third Credit Card)		2022002897	PC_SI_Concrete for Riverview Project
			12/31/2022	CC:65351	\$	(73.72)	07600 (Fifth Third Credit Card)		2022003251	P&C_Brad H's Nov 2022 cc ref: 2022000133
			12/31/2022	CC:65351	\$	461.91	07600 (Fifth Third Credit Card)		2022003252	CC_Brad H's Nov 2022 cc ref: 2022000133
100.5003.570200	LAND IMPROVEMENTS - CR		12/2/2022	6021171	\$	179.80	4887 (Green Earth Transportation)		2022000641	SE_APT Top Dressing Stone
100.5004.530900	OTHER OP MTRLS & SUPPLIES - OPS		12/16/2022	6021283	\$	482.39	06278 (Vance Outdoors, Inc.)		2022003137	Remainder balance for prior Vance's invoices
			12/31/2022	CC:65351	\$	297.11	07600 (Fifth Third Credit Card)		2022003253	OPS_Brad N. Nov 2022 cc ref: 2022000133
			12/31/2022	CC:65351	\$	119.07	07600 (Fifth Third Credit Card)		2022003272	OPS_jim's Nov 2022 cc ref: 2022000133
100.5004.557100	UNIFORMS - OPS		12/2/2022	6021183	\$	42.25	01227 (Superior Uniform Sales, Inc.)		2022000268	OPS_M_Elton uniform allowance
			12/2/2022	6021183	\$	575.45	01227 (Superior Uniform Sales, Inc.)		2022002082	Start up uniforms for Bobbie-Jo
			12/2/2022	6021183	\$	987.45	01227 (Superior Uniform Sales, Inc.)		2022002083	Start up uniforms for Darriontae
			12/2/2022	6021183	\$	900.00	01227 (Superior Uniform Sales, Inc.)		2022002471	Start up uniforms for Scott Germani
			12/2/2022	6021183	\$	900.00	01227 (Superior Uniform Sales, Inc.)		2022002498	Start up uniforms for Steven Mendez
			12/2/2022	6021183	\$	564.00	01227 (Superior Uniform Sales, Inc.)		2022002499	Start up uniforms for Corey Cole
			12/9/2022	6021208	\$	260.97	02309 (Galls, LLC)		2022000268	OPS_M_Elton uniform allowance
			12/9/2022	6021221	\$	330.00	5653 (PGN Consulting)		2022002496	Hats for rangers
			12/9/2022	6021226	\$	295.49	01227 (Superior Uniform Sales, Inc.)		2022000327	OPS_J_Schneider uniform allowance
			12/9/2022	6021226	\$	153.50	01227 (Superior Uniform Sales, Inc.)		2022000332	OPS_E_Varner uniform allowance
			12/16/2022	6021254	\$	243.36	08615 (AIA Corporation)		2022000263	OPS_D_Connolly uniform allowance
			12/16/2022	6021254	\$	116.00	08615 (AIA Corporation)		2022001569	Polo shirts for ranger trainee
			12/16/2022	6021277	\$	297.96	01227 (Superior Uniform Sales, Inc.)		2022002499	Start up uniforms for Corey Cole
			12/31/2022	CC:65351	\$	204.98	07600 (Fifth Third Credit Card)		2022003253	OPS_Brad N. Nov 2022 cc ref: 2022000133
			12/31/2022	CC:65355	\$	119.99	01227 (Superior Uniform Sales, Inc.)		2022002082	Start up uniforms for Bobbie-Jo
100.5004.558400	FLEET VEH. REPAIR		12/9/2022	6021200	\$	634.68	03304 (Charlie's Dodge, Inc.)		2022003019	Unforeseen additional charges to Jeep patrol car repair
			12/31/2022	CC:65351	\$	914.73	07600 (Fifth Third Credit Card)		2022003227	OPS_Greg's Nov 2022 cc ref: 2022000133
			12/31/2022	CC:65351	\$	1,134.05	07600 (Fifth Third Credit Card)		2022003253	OPS_Brad N. Nov 2022 cc ref: 2022000133
			12/31/2022	CC:65351	\$	118.96	07600 (Fifth Third Credit Card)		2022003272	OPS_jim's Nov 2022 cc ref: 2022000133
			12/31/2022	CC:65351	\$	1,002.25	07600 (Fifth Third Credit Card)		2022003244	GC_Lorenzo's Nov 2022 cc ref: 2022000133
100.6000.520800	MILEAGE - OPS		12/2/2022	6021158	\$	229.44	5502 (Zach Becker)		2022002850	OPS_Year end mileage reimbursements
			12/2/2022	6021159	\$	187.50	5600 (Lisa Whitton)		2022002850	OPS_Year end mileage reimbursements
			12/9/2022	6021234	\$	311.25	08351 (Anthony Amstutz)		2022002850	OPS_Year end mileage reimbursements
			12/9/2022	6021251	\$	210.06	5502 (Zach Becker)		2022002850	OPS_Year end mileage reimbursements
100.6000.530100	SM EQUIP/ FURN/ FIXTURES - OPS		12/16/2022	6021283	\$	1,405.61	06278 (Vance Outdoors, Inc.)		2021000605	OPS_Replacement Firearms for the Rangers
			12/16/2022	6021283	\$	304.00	06278 (Vance Outdoors, Inc.)		2021000605	OPS_Replacement Firearms for the Rangers
			12/16/2022	6021283	\$	133.50	06278 (Vance Outdoors, Inc.)		2021000605	OPS_Replacement Firearms for the Rangers
100.6000.530900	OTHER OP MTRLS & SUPPLIES - OPS		12/16/2022	6021283	\$	3,851.60	06278 (Vance Outdoors, Inc.)		2021002951	OPS_Ammunition for ranger firearms training & qualifications

100.6000.533300	ROAD SALT - OPS	12/16/2022	67363	\$	1,436.66	5492 (Morton Salt, Inc.)	2022002322	OPER_Bulk road salt		
		12/23/2022	67381	\$	1,525.22	5492 (Morton Salt, Inc.)	2022002322	OPER_Bulk road salt		
		12/16/2022	6021272	\$	7,732.60	5261 (Renewed Outdoors, LLC)	2022002502	OPS_Bagged ice melt and rock salt		
100.6000.540100	DISPOSAL - OPS	12/9/2022	9879	\$	1,075.00	05540 (Republic Services)	2022000134	OPS_Recycling and waste disposal services		
		12/9/2022	9879	\$	5,766.00	05540 (Republic Services)	2022000134	OPS_Recycling and waste disposal services		
		12/16/2022	9896	\$	490.59	05540 (Republic Services)	2022000134	OPS_Recycling and waste disposal services		
		12/23/2022	9905	\$	413.66	01536 (Waste Management)	2022000114	OPS_Recycling and waste disposal services		
100.6000.540500	GAS/ DIESEL - OPS	12/30/2022	9917	\$	18,478.97	06427 (Wex Bank)	2022000136	OPS_Fuel for fleet vehicles		
100.6000.550100	CONFERENCES/ TRAINING - OPS	12/31/2022	CC:65351	\$	9.45	07600 (Fifth Third Credit Card)	2022003247	OPS_Nate's Nov 2022 cc ref: 2022000133		
		12/31/2022	CC:65351	\$	1,216.05	07600 (Fifth Third Credit Card)	2022003224	OQ_Mackenzie's Nov 2022 cc ref: 2022000133		
		12/31/2022	CC:65351	\$	160.00	07600 (Fifth Third Credit Card)	2022003264	PRG_Shannon's Nov 2022 cc ref: 2022000133		
		12/31/2022	CC:65351	\$	144.00	07600 (Fifth Third Credit Card)	2022003244	GC_Lorenzo's Nov 2022 cc ref: 2022000133		
100.6000.552700	OTHER EQUIPMENT REPAIR - OPS	12/9/2022	6021200	\$	4,755.23	03304 (Charlie's Dodge, Inc.)	2022002536	OPS_Repairs to 2019 Jeep Trailhawk (South)		
100.6000.557100	UNIFORMS - OPS	12/2/2022	6021179	\$	123.48	5653 (PGN Consulting)	2022000276	OPS_N. Ramsey Uniform Allowance		
		12/2/2022	6021183	\$	159.25	01227 (Superior Uniform Sales, Inc.)	2022000281	OPS_J. Milbrodt uniform allowance		
		12/2/2022	6021183	\$	168.00	01227 (Superior Uniform Sales, Inc.)	2022000284	OPS_T. Ankenbrandt uniform allowance		
		12/2/2022	6021183	\$	131.49	01227 (Superior Uniform Sales, Inc.)	2022000290	OPS_A. Szabo uniform allowance		
		12/2/2022	6021183	\$	221.00	01227 (Superior Uniform Sales, Inc.)	2022000304	OPS_S. Stockford uniform allowance		
		12/2/2022	6021183	\$	328.50	01227 (Superior Uniform Sales, Inc.)	2022000311	OPS_Z. Becker uniform allowance		
		12/2/2022	6021183	\$	106.25	01227 (Superior Uniform Sales, Inc.)	2022000314	OPS_D. Zemnicky uniform allowance		
		12/2/2022	6021183	\$	115.00	01227 (Superior Uniform Sales, Inc.)	2022000319	OPS_N. Smith uniform allowance		
		12/2/2022	6021183	\$	159.75	01227 (Superior Uniform Sales, Inc.)	2022000330	OPS_Start up uniform maintenance 2		
		12/2/2022	6021183	\$	304.00	01227 (Superior Uniform Sales, Inc.)	2022001707	OPS_R. Dammarell uniform start up allotment		
		12/9/2022	6021195	\$	82.30	08615 (AIA Corporation)	2022000400	OPS_E. Main 2022 uniform allowance		
		12/9/2022	6021221	\$	53.00	5653 (PGN Consulting)	2022000297	OPS_Jim Ankenbrandt uniform allowance		
		12/9/2022	6021226	\$	49.25	01227 (Superior Uniform Sales, Inc.)	2022000321	OPS_B. Heckman uniform allowance		
		12/16/2022	6021254	\$	39.90	08615 (AIA Corporation)	2022000271	OPS_M. Keip Uniform Allowance		
		12/16/2022	6021254	\$	10.00	08615 (AIA Corporation)	2022000277	OPS_D. Sanderson uniform allowance		
		12/16/2022	6021254	\$	69.85	08615 (AIA Corporation)	2022000281	OPS_J. Milbrodt uniform allowance		
		12/16/2022	6021254	\$	19.95	08615 (AIA Corporation)	2022000292	OPS_B. Braley uniform allowance		
		12/16/2022	6021254	\$	143.00	08615 (AIA Corporation)	2022000302	OPS_L. Whitton start up uniforms		
		12/16/2022	6021277	\$	196.49	01227 (Superior Uniform Sales, Inc.)	2022000286	OPS_J. Lohman uniform allowance		
		12/16/2022	6021277	\$	8.12	01227 (Superior Uniform Sales, Inc.)	2022000295	OPS_H. Ellers uniform allowance		
		12/23/2022	6021294	\$	267.99	08615 (AIA Corporation)	2022000272	OPS_B. Hooven uniform allowance		
		12/23/2022	6021294	\$	72.27	08615 (AIA Corporation)	2022000280	OPS_L. Poca uniform allowance		
		12/23/2022	6021294	\$	22.02	08615 (AIA Corporation)	2022000285	OPS_K. Bonner Uniform Allowance		
		12/23/2022	6021294	\$	4.52	08615 (AIA Corporation)	2022000318	OPS_B. Pollick uniform allowance		
		12/23/2022	6021294	\$	29.95	08615 (AIA Corporation)	2022000326	OPS_Start up uniform maintenance 1		
		12/23/2022	6021294	\$	1.27	08615 (AIA Corporation)	2022000330	OPS_Start up uniform maintenance 2		
		12/31/2022	CC:65351	\$	119.99	07600 (Fifth Third Credit Card)	2022000290	OPS_A. Szabo uniform allowance		
		100.6000.557110	LOGO-WEAR UNIFORM NON CONTRACTUAL - OPS	12/9/2022	6021195	\$	524.88	08615 (AIA Corporation)	2022002360	OPS_seasonal employee uniform items
				12/9/2022	6021235	\$	74.98	5750 (Bryan Dunlap)	2022000801	OPS_Seasonal employee boot allowance
				12/9/2022	6021249	\$	100.00	5720 (Tom Rudolph)	2022000801	OPS_Seasonal employee boot allowance
		100.6000.558500	Rolling Stock Repair	12/2/2022	6021161	\$	58.12	01864 (Century Equipment)	2022000369	OPS_Repairs to wide area mower
		100.6001.530900	OTHER OP MTRLS & SUPPLIES - PE	12/9/2022	6021213	\$	163.46	5496 (KSS Enterprises)	2022002914	PE_parts for floor scrubber
12/16/2022	6021254			\$	119.70	08615 (AIA Corporation)	2022000139	PE_staff hats		
12/16/2022	6021254			\$	59.85	08615 (AIA Corporation)	2022001311	PE_Bucket Hats		
12/31/2022	CC:65351			\$	396.60	07600 (Fifth Third Credit Card)	2022003268	PE_Ryan Nov 2022 ref: 2022000133		
100.6001.531801	CLEANING SUPPLIES - HM	12/9/2022	6021207	\$	339.55	06733 (Fastenal Company)	2022002401	HM_cleaning supplies		
		12/9/2022	6021207	\$	280.18	06733 (Fastenal Company)	2022002401	HM_cleaning supplies		
100.6001.540300	WATER - PE	12/16/2022	9888	\$	364.32	01896 (City of Oregon-Water)	2022000065	PE_Water usage		
		12/16/2022	9888	\$	110.78	01896 (City of Oregon-Water)	2022000065	PE_Water usage		
		12/16/2022	9888	\$	728.64	01896 (City of Oregon-Water)	2022000065	PE_Water usage		
		12/16/2022	9888	\$	916.88	01896 (City of Oregon-Water)	2022000065	PE_Water usage		
100.6001.540400	ELECTRIC - PE	12/9/2022	9881	\$	1,189.91	01320 (Toledo Edison)	2022000054	PE_Electric usage		
		12/16/2022	9884	\$	18.88	01320 (Toledo Edison)	2022000054	PE_Electric usage		
		12/30/2022	9915	\$	355.55	01320 (Toledo Edison)	2022000054	PE_Electric usage		
100.6001.540401	ELECTRIC - HM	12/30/2022	9915	\$	208.91	01320 (Toledo Edison)	2022000082	HM_Electric usage (Howard Marsh restroom)		
100.6001.540500	GAS/ DIESEL - PE	12/2/2022	6021169	\$	1,133.45	06786 (Gary Schumaker LLC)	2022000081	PE_Diesel Fuel		
100.6001.540600	HEATING FUEL - PE	12/16/2022	9885	\$	269.10	00447 (Amerigas - 5678)	2022000062	PE_Gas usage		
		12/16/2022	9890	\$	841.15	01924 (Columbia Gas)	2022000062	PE_Gas usage		
		12/30/2022	9908	\$	846.96	00447 (Amerigas - 5678)	2022000062	PE_Gas usage		

100.6001.551900	MISC CONTRACT SVCS - PE	12/23/2022	67374	\$	2,585.50	5712 (Cousino Restoration & Environmental LLC)	2022002869	PE_lodge restoration
		12/16/2022	6021274	\$	741.00	08435 (Rose Pest Solutions)	2022003203	PE_pest control
100.6001.551901	MISC CONTRACT SVCS - HM	12/16/2022	6021256	\$	115.00	05234 (Co-Man)	2022002715	HM_portapot
		12/16/2022	6021267	\$	395.60	07089 (Nissen Concrete)	2022002760	HM_concrete
100.6001.552500	TREE WORK - PE	12/9/2022	67354	\$	1,480.00	04104 (T & J Excavating & Tree Clearing LLC)	2022002732	PE_stump grinding
100.6001.558300	Facility Systems Services	12/9/2022	6021199	\$	1,101.00	4631 (Coleman Systems, Inc.)	2022002904	PE_furnace repairs
100.6001.558400	Fleet Veh. Repair	12/16/2022	6021282	\$	1,064.00	01425 (Tri County Tire, Inc.)	2022002837	PE_tires for dump truck
		12/31/2022	CC:65351	\$	50.00	07600 (Fifth Third Credit Card)	2022003268	PE_Ryan Nov 2022 ref: 2022000133
100.6001.558500	Rolling Stock Repair	12/16/2022	6021282	\$	145.00	01425 (Tri County Tire, Inc.)	2022002842	PE_battery for tractor
		12/31/2022	CC:65351	\$	31.64	07600 (Fifth Third Credit Card)	2022003268	PE_Ryan Nov 2022 ref: 2022000133
100.6002.530900	OTHER OP MTRLS & SUPPLIES - SI	12/31/2022	CC:65351	\$	645.96	07600 (Fifth Third Credit Card)	2022003240	SI_Bob's Nov 2022 cc ref: 2022000133
100.6002.531800	CLEANING SUPPLIES - SI	12/16/2022	6021262	\$	428.41	5496 (KSS Enterprises)	2022003069	SI_cleaning supplies
		12/23/2022	6021317	\$	347.84	5496 (KSS Enterprises)	2022003069	SI_cleaning supplies
		12/31/2022	CC:65351	\$	206.91	07600 (Fifth Third Credit Card)	2022003240	SI_Bob's Nov 2022 cc ref: 2022000133
100.6002.533600	Ops. M&S-Grounds	12/31/2022	CC:65351	\$	14.00	07600 (Fifth Third Credit Card)	2022003240	SI_Bob's Nov 2022 cc ref: 2022000133
100.6002.533800	Ops. M&S-Paper Products	12/16/2022	6021262	\$	1,119.25	5496 (KSS Enterprises)	2022002873	SI_paper products
		12/16/2022	6021262	\$	134.14	5496 (KSS Enterprises)	2022002873	SI_paper products
		12/16/2022	6021262	\$	229.90	5496 (KSS Enterprises)	2022002873	SI_paper products
100.6002.540200	SEPTIC - SI	12/23/2022	6021327	\$	400.00	00370 (Randy Mastin Septic Tank, Inc.)	2022000076	SI-Septic
		12/23/2022	6021327	\$	575.00	00370 (Randy Mastin Septic Tank, Inc.)	2022000076	SI-Septic
		12/23/2022	6021327	\$	300.00	00370 (Randy Mastin Septic Tank, Inc.)	2022000076	SI-Septic
100.6002.540300	WATER - SI	12/9/2022	9877	\$	36.79	02063 (Department of Public Utilities)	2022000071	SI/FA_Water usage
		12/9/2022	9877	\$	22.29	02063 (Department of Public Utilities)	2022000071	SI/FA_Water usage
		12/9/2022	9877	\$	17.45	02063 (Department of Public Utilities)	2022000071	SI/FA_Water usage
		12/16/2022	9887	\$	21.96	03678 (City of Maumee)	2022000071	SI/FA_Water usage
		12/16/2022	9887	\$	241.56	03678 (City of Maumee)	2022000071	SI/FA_Water usage
100.6002.540400	ELECTRIC - SI	12/16/2022	9884	\$	619.07	01320 (Toledo Edison)	2022000047	SI_Electric usage Cannonball Prairie
		12/23/2022	9904	\$	22.95	01320 (Toledo Edison)	2022000047	SI_Electric usage Cannonball Prairie
		12/30/2022	9915	\$	140.51	01320 (Toledo Edison)	2022000047	SI_Electric usage Cannonball Prairie
100.6002.540500	GAS/ DIESEL - SI	12/2/2022	6021162	\$	1,163.19	07538 (Brahier Oil, Inc.)	2022000070	SI/FA_Fuel/Fuel Delivery
100.6002.540600	HEATING FUEL - SI	12/9/2022	9875	\$	676.66	00447 (Amerigas - 5678)	2022000058	SI/FA_Gas usage
		12/16/2022	9885	\$	233.21	00447 (Amerigas - 5678)	2022000058	SI/FA_Gas usage
		12/23/2022	9901	\$	109.03	01924 (Columbia Gas)	2022000058	SI/FA_Gas usage
		12/30/2022	9909	\$	414.60	01924 (Columbia Gas)	2022000058	SI/FA_Gas usage
		12/30/2022	9909	\$	256.55	01924 (Columbia Gas)	2022000058	SI/FA_Gas usage
		12/30/2022	9909	\$	196.06	01924 (Columbia Gas)	2022000058	SI/FA_Gas usage
100.6002.551900	MISC CONTRACT SVCS - SI	12/16/2022	6021256	\$	115.00	05234 (Co-Man)	2022001622	SI_emergency porta john rental for riverview restroom
		12/16/2022	6021256	\$	130.00	05234 (Co-Man)	2022001622	SI_emergency porta john rental for riverview restroom
100.6002.552700	OTHER EQUIPMENT REPAIR - SI	12/31/2022	CC:65351	\$	135.36	07600 (Fifth Third Credit Card)	2022003240	SI_Bob's Nov 2022 cc ref: 2022000133
100.6003.530100	SM EQUIP/ FURN/ FIXTURES - PR	12/31/2022	CC:65351	\$	227.49	07600 (Fifth Third Credit Card)	2022003254	DW-6033_Brian_Nov 2022 cc ref: 2022000133
100.6003.530900	OTHER OP MTRLS & SUPPLIES - FA/PR	12/16/2022	67368	\$	13.99	01541 (Waterville Hardware & Paint)	2022002076	FA_Assorted Supplies
		12/16/2022	67368	\$	40.95	01541 (Waterville Hardware & Paint)	2022002076	FA_Assorted Supplies
		12/31/2022	CC:65351	\$	718.11	07600 (Fifth Third Credit Card)	2022003256	FA-Brian's Nov 2022 cc ref: 2022000133
		12/31/2022	CC:65351	\$	684.81	07600 (Fifth Third Credit Card)	2022003254	DW-6033_Brian_Nov 2022 cc ref: 2022000133
		12/31/2022	CC:65358	\$	673.44	05631 (Menards)	2022002797	PR_Foam Board and OSB for Lean-To
100.6003.531800	CLEANING SUPPLIES - PR	12/16/2022	6021262	\$	286.61	5496 (KSS Enterprises)	2022002935	PR_Paper Products
100.6003.533600	Ops. M&S-Grounds	12/9/2022	6021219	\$	28.00	08293 (Ohio Compost and Recycling, LLC)	2022001240	FA_Mulch
100.6003.533700	Ops. M&S-Equip.	12/16/2022	67357	\$	31.94	5514 (Ag-Pro Ohio, LLC)	2022002681	PR_Spark Plugs and Filters
		12/31/2022	CC:65351	\$	336.99	07600 (Fifth Third Credit Card)	2022003256	FA-Brian's Nov 2022 cc ref: 2022000133
100.6003.540200	SEPTIC - PR	12/23/2022	6021327	\$	500.00	00370 (Randy Mastin Septic Tank, Inc.)	2022002798	PR/FA_Septic Pumping
		12/23/2022	6021327	\$	700.00	00370 (Randy Mastin Septic Tank, Inc.)	2022002798	PR/FA_Septic Pumping
100.6003.540300	WATER - FA/PR	12/16/2022	9889	\$	45.06	01493 (City of Waterville)	2022000086	PR_Water usage
		12/16/2022	9889	\$	19.81	01493 (City of Waterville)	2022000086	PR_Water usage
		12/16/2022	9889	\$	10.88	01493 (City of Waterville)	2022000086	PR_Water usage

		12/16/2022	9889	\$	10.88	01493 (City of Waterville)	2022000086	PR_Water usage
		12/16/2022	9889	\$	36.13	01493 (City of Waterville)	2022000086	PR_Water usage
		12/16/2022	9889	\$	28.74	01493 (City of Waterville)	2022000086	PR_Water usage
		12/16/2022	9894	\$	509.77	01495 (Village of Grand Rapids)	2022000086	PR_Water usage
100.6003.540400	ELECTRIC - FA/PR	12/23/2022	9904	\$	608.70	01320 (Toledo Edison)	2022000068	PR_Electric usage 13803 US Highway 24
100.6003.540600	HEATING FUEL - PR	12/9/2022	9880	\$	48.88	01209 (Suburban Natural Gas Co.)	2022000060	PR_Gas usage
		12/9/2022	9880	\$	146.46	01209 (Suburban Natural Gas Co.)	2022000060	PR_Gas usage
100.6003.551900	MISC CONTRACT SVCS - FA/PR	12/9/2022	6021212	\$	6,273.00	05542 (Jacob Coolman)	2022000869	PR_Hoagie Contract
		12/16/2022	6021256	\$	215.00	05234 (Co-Man)	2022002814	BV_Portable Toilet Rental
		12/31/2022	CC:65351	\$	(191.07)	07600 (Fifth Third Credit Card)	2022003270	BC_Zach Nov 2022 cc ref: 2022000133
100.6003.558400	Fleet Veh. Repair	12/31/2022	CC:65351	\$	158.40	07600 (Fifth Third Credit Card)	2022003254	DW-6033_Brian_Nov 2022 cc ref: 2022000133
		12/31/2022	CC:65351	\$	1,120.90	07600 (Fifth Third Credit Card)	2022003256	FA-Brian's Nov 2022 cc ref: 2022000133
100.6004.530100	SM EQUIP/ FURN/ FIXTURES - SE	12/31/2022	CC:65351	\$	20.00	07600 (Fifth Third Credit Card)	2022003258	SE_Devin's Nov 2022 cc ref: 2022000133
100.6004.530101	SM EQUIP/ FURN/ FIXTURES - WG	12/16/2022	67357	\$	855.00	5514 (Ag-Pro Ohio, LLC)	2022002770	SE_Power Equipment
100.6004.530900	OTHER OP MTRLS & SUPPLIES - SE	12/16/2022	9892	\$	103.25	04571 (Lowe's)	2022003231	DW_Lowe's Dec 2022 paym ref: 2022000143
		12/16/2022	6021253	\$	412.97	02411 (Affiliated Cash & Carry, Inc.)	2021003063	SE_lumber for bridges and picnic tables
		12/16/2022	6021253	\$	667.63	02411 (Affiliated Cash & Carry, Inc.)	2021003063	SE_lumber for bridges and picnic tables
		12/31/2022	CC:65351	\$	39.98	07600 (Fifth Third Credit Card)	2022003242	OPER_Anthony's Nov 2022 cc ref: 2022000133
		12/31/2022	CC:65351	\$	245.75	07600 (Fifth Third Credit Card)	2022003258	SE_Devin's Nov 2022 cc ref: 2022000133
		12/31/2022	CC:65351	\$	46.00	07600 (Fifth Third Credit Card)	2022003241	MKTG_Val's Nov 2022 cc ref: 2022000133
100.6004.530901	OTHER OP MTRLS & SUPPLIES - WG	12/31/2022	CC:65351	\$	490.80	07600 (Fifth Third Credit Card)	2022003258	SE_Devin's Nov 2022 cc ref: 2022000133
100.6004.530902	OTHER OP MTRLS & SUPPLIES - WE	12/31/2022	CC:65351	\$	4,329.18	07600 (Fifth Third Credit Card)	2022003242	OPER_Anthony's Nov 2022 cc ref: 2022000133
100.6004.531100	OFFICE SUPPLIES - SE	12/16/2022	6021260	\$	160.20	06733 (Fastenal Company)	2022003035	SE_Office supplies
		12/31/2022	CC:65351	\$	145.99	07600 (Fifth Third Credit Card)	2022003242	OPER_Anthony's Nov 2022 cc ref: 2022000133
100.6004.531800	CLEANING SUPPLIES - SE	12/23/2022	6021308	\$	434.80	06733 (Fastenal Company)	2022003188	SE_Cleaning Supplies
		12/31/2022	CC:65351	\$	39.98	07600 (Fifth Third Credit Card)	2022003242	OPER_Anthony's Nov 2022 cc ref: 2022000133
100.6004.533600	Ops. M&S-Grounds	12/9/2022	67342	\$	275.00	03156 (City of Toledo)	2022002180	SE_Playground Mulch
		12/2/2022	6021171	\$	220.20	4887 (Green Earth Transportation)	2022002338	SE_Trail Stone
100.6004.533900	Ops. M&S-Cleaning Supplies	12/9/2022	6021207	\$	176.19	06733 (Fastenal Company)	2022002941	SE_Cleaning Supplies
100.6004.540200	SEPTIC - SE	12/23/2022	6021327	\$	300.00	00370 (Randy Mastin Septic Tank, Inc.)	2022002699	SE_Walnut Grove Septic Service
100.6004.540400	ELECTRIC - SE	12/16/2022	9884	\$	469.03	01320 (Toledo Edison)	2022000063	SE_Electric usage
		12/30/2022	9915	\$	70.92	01320 (Toledo Edison)	2022000063	SE_Electric usage
100.6004.540500	GAS/ DIESEL - SE	12/16/2022	6021257	\$	936.20	08250 (Crystal Flash)	2022000088	SE_Park fuel
100.6004.540600	HEATING FUEL - SE	12/9/2022	9875	\$	1,062.47	00447 (Amerigas - 5678)	2022000140	SE_Gas usage
		12/16/2022	9885	\$	607.18	00447 (Amerigas - 5678)	2022000140	SE_Gas usage
100.6004.551900	MISC CONTRACT SVCS - SE	12/9/2022	6021224	\$	179.90	5003 (Protegis Fire & Safety)	2022002286	SE_Annual Fire Extinguisher Inspections
		12/16/2022	6021274	\$	60.00	08435 (Rose Pest Solutions)	2022002133	SE_Pest Control
		12/23/2022	6021320	\$	690.00	5316 (Merit Plumbing, Inc.)	2022003070	SE_Main water line repair
100.6004.551901	MISC CONTRACT SVCS - WG	12/9/2022	6021201	\$	119.43	05234 (Co-Man)	2022000419	SE_restroom rentals
100.6004.551902	MISC CONTRACT SVCS - WE	12/9/2022	6021201	\$	33.50	05234 (Co-Man)	2022000419	SE_restroom rentals
100.6004.552700	OTHER EQUIPMENT REPAIR - SE	12/31/2022	CC:65351	\$	55.52	07600 (Fifth Third Credit Card)	2022003258	SE_Devin's Nov 2022 cc ref: 2022000133
100.6004.558500	Rolling Stock Repair	12/31/2022	CC:65351	\$	250.38	07600 (Fifth Third Credit Card)	2022003258	SE_Devin's Nov 2022 cc ref: 2022000133
100.6005.530900	OTHER OP MTRLS & SUPPLIES - OO	12/16/2022	9892	\$	329.11	04571 (Lowe's)	2022003231	DW_Lowe's Dec 2022 paym ref: 2022000143
		12/2/2022	6021170	\$	11.96	02374 (Grainger)	2022002854	OO_Parts for Locks
		12/9/2022	6021207	\$	1,749.31	06733 (Fastenal Company)	2022002511	OO_Vending Machine Restock November
		12/9/2022	6021207	\$	170.27	06733 (Fastenal Company)	2022002511	OO_Vending Machine Restock November
		12/16/2022	6021261	\$	443.80	07599 (Fessenden Hardware)	2022002761	OO_Shop Materials and Supplies
		12/31/2022	CC:65351	\$	360.64	07600 (Fifth Third Credit Card)	2022003224	OO_Mackenzie's Nov 2022 cc ref: 2022000133
		12/31/2022	CC:65351	\$	255.21	07600 (Fifth Third Credit Card)	2022003226	OO_Brandon's Nov 2022 cc ref: 2022000133
		12/31/2022	CC:65357	\$	160.00	04384 (NAI)	2022002841	OO_CIH Training THV staff
100.6005.540300	WATER - OO	12/9/2022	9882	\$	168.82	01897 (City of Toledo Department of Public Utilities)	2022000083	OO_Water usage
		12/16/2022	9895	\$	245.67	08674 (Village of Swanton)	2022000083	OO_Water usage
		12/16/2022	9895	\$	61.77	08674 (Village of Swanton)	2022000083	OO_Water usage

100.6005.540400	ELECTRIC - OO	12/9/2022	9881	\$	79.04	01320 (Toledo Edison)	2022000123	OO/FA Electric usage
		12/9/2022	9881	\$	426.24	01320 (Toledo Edison)	2022000123	OO/FA Electric usage
		12/16/2022	9884	\$	1,470.24	01320 (Toledo Edison)	2022000123	OO/FA Electric usage
		12/30/2022	9915	\$	82.54	01320 (Toledo Edison)	2022000123	OO/FA Electric usage
		12/30/2022	9915	\$	66.08	01320 (Toledo Edison)	2022000123	OO/FA Electric usage
		12/30/2022	9915	\$	143.43	01320 (Toledo Edison)	2022000123	OO/FA Electric usage
		12/30/2022	9915	\$	244.35	01320 (Toledo Edison)	2022000123	OO/FA Electric usage
		12/30/2022	9915	\$	255.16	01320 (Toledo Edison)	2022000123	OO/FA Electric usage
12/30/2022	9915	\$	81.15	01320 (Toledo Edison)	2022000123	OO/FA Electric usage		
100.6005.540402	ELECTRIC - TREEHOUSES	12/30/2022	9915	\$	1,020.12	01320 (Toledo Edison)	2022000074	THV_Electric Treehouse
100.6005.540600	HEATING FUEL - OO	12/9/2022	9875	\$	158.72	00447 (Amerigas - 5678)	2022000139	OO_Gas usage
		12/9/2022	9875	\$	1,368.45	00447 (Amerigas - 5678)	2022000139	OO_Gas usage
		12/9/2022	9878	\$	131.23	04330 (Ohio Gas Company)	2022000139	OO_Gas usage
		12/16/2022	9885	\$	244.33	00447 (Amerigas - 5678)	2022000139	OO_Gas usage
		12/16/2022	9885	\$	488.52	00447 (Amerigas - 5678)	2022000139	OO_Gas usage
		12/16/2022	9885	\$	220.23	00447 (Amerigas - 5678)	2022000139	OO_Gas usage
		12/30/2022	9908	\$	1,288.09	00447 (Amerigas - 5678)	2022000139	OO_Gas usage
		12/30/2022	9913	\$	274.69	04330 (Ohio Gas Company)	2022000139	OO_Gas usage
12/30/2022	9913	\$	134.16	04330 (Ohio Gas Company)	2022000139	OO_Gas usage		
100.6005.551900	MISC CONTRACT SVCS - OO	12/2/2022	6021171	\$	6.40	4887 (Green Earth Transportation)	2022002285	OO_Top Soil for Lodge
		12/16/2022	6021256	\$	170.00	05234 (Co-Man)	2022003167	OO_Porta John Rentals
		12/16/2022	6021256	\$	260.00	05234 (Co-Man)	2022003167	OO_Porta John Rentals
		12/16/2022	6021256	\$	260.00	05234 (Co-Man)	2022003167	OO_Porta John Rentals
		12/16/2022	6021263	\$	242.40	00325 (Luce's Chimney & Stove Shop, Limited)	2022002517	OO_Chimney Repair at Pine Ridge
100.6005.558300	Facility Systems Services	12/2/2022	6021163	\$	438.00	4631 (Coleman Systems, Inc.)	2022002849	OO_HVAC repairs
100.6006.530100	SM EQUIP/ FURN/ FIXTURES - SW	12/16/2022	9891	\$	273.42	06188 (Home Depot Credit Services)	2022003107	DW_November 2022 credit acct-ref: PO2022000078
		12/31/2022	CC:65351	\$	169.99	07600 (Fifth Third Credit Card)	2022003228	SW_Kevin's Nov 2022 cc ref: 2022000133
100.6006.530900	OTHER OP MTRLS & SUPPLIES - SW	12/16/2022	9891	\$	160.53	06188 (Home Depot Credit Services)	2022002805	DW_October 2022 credit acct-ref: PO2022000078
		12/16/2022	6021279	\$	324.91	01287 (Titgemeier's)	2022000158	SW_WOW birdseed
		12/31/2022	CC:65351	\$	1,197.90	07600 (Fifth Third Credit Card)	2022003228	SW_Kevin's Nov 2022 cc ref: 2022000133
100.6006.531800	CLEANING SUPPLIES - SW	12/9/2022	6021207	\$	822.11	06733 (Fastenal Company)	2022002400	SW Vending Restock 2
100.6006.540300	WATER - SW	12/9/2022	9877	\$	108.92	02063 (Department of Public Utilities)	2022000115	SW_Water usage Hill Ave Keil Farms-Copeland Blvd
		12/16/2022	9883	\$	9.80	02063 (Department of Public Utilities)	2022000115	SW_Water usage Hill Ave Keil Farms-Copeland Blvd
		12/16/2022	9883	\$	214.17	02063 (Department of Public Utilities)	2022000115	SW_Water usage Hill Ave Keil Farms-Copeland Blvd
		12/16/2022	9883	\$	102.25	02063 (Department of Public Utilities)	2022000115	SW_Water usage Hill Ave Keil Farms-Copeland Blvd
		12/16/2022	9883	\$	85.98	02063 (Department of Public Utilities)	2022000115	SW_Water usage Hill Ave Keil Farms-Copeland Blvd
		12/16/2022	9883	\$	459.18	02063 (Department of Public Utilities)	2022000115	SW_Water usage Hill Ave Keil Farms-Copeland Blvd
		12/16/2022	9883	\$	102.25	02063 (Department of Public Utilities)	2022000115	SW_Water usage Hill Ave Keil Farms-Copeland Blvd
		12/30/2022	9911	\$	3.80	02063 (Department of Public Utilities)	2022000115	SW_Water usage Hill Ave Keil Farms-Copeland Blvd
		100.6006.540400	ELECTRIC - SW	12/16/2022	9884	\$	491.70	01320 (Toledo Edison)
12/23/2022	9904	\$	83.40	01320 (Toledo Edison)	2022000056	SW_Electric usage		
12/23/2022	9904	\$	166.34	01320 (Toledo Edison)	2022000056	SW_Electric usage		
12/23/2022	9904	\$	281.77	01320 (Toledo Edison)	2022000056	SW_Electric usage		
100.6006.540600	HEATING FUEL - SW	12/23/2022	9901	\$	859.57	01924 (Columbia Gas)	2022000064	SW_Gas usage
		12/23/2022	9901	\$	186.62	01924 (Columbia Gas)	2022000064	SW_Gas usage
		12/23/2022	9901	\$	370.71	01924 (Columbia Gas)	2022000064	SW_Gas usage
		12/23/2022	9901	\$	189.21	01924 (Columbia Gas)	2022000064	SW_Gas usage
		12/23/2022	9901	\$	175.39	01924 (Columbia Gas)	2022000064	SW_Gas usage
100.6006.551900	MISC CONTRACT SVCS - SW	12/9/2022	6021223	\$	66.00	08435 (Rose Pest Solutions)	2022001248	SW_Pest Management
		12/16/2022	6021270	\$	115.00	5003 (Protegis Fire & Safety)	2022003162	SW_Fire extinguisher inspection
		12/16/2022	6021274	\$	692.00	08435 (Rose Pest Solutions)	2022001248	SW_Pest Management
100.6006.558500	Rolling Stock Repair	12/16/2022	67357	\$	26.91	5514 (Ag-Pro Ohio, LLC)	2022002682	SW_Mower parts
		12/31/2022	CC:65351	\$	1,258.48	07600 (Fifth Third Credit Card)	2022003228	SW_Kevin's Nov 2022 cc ref: 2022000133
100.6007.530100	SM EQUIP/ FURN/ FIXTURES - WW	12/31/2022	CC:65351	\$	517.89	07600 (Fifth Third Credit Card)	2022003245	WW_Graem's Nov 2022 cc ref: 2022000133
100.6007.530900	OTHER OP MTRLS & SUPPLIES - WW	12/16/2022	9892	\$	59.77	04571 (Lowe's)	2022003231	DW_Lowe's Dec 2022 paym ref: 2022000143
		12/9/2022	6021198	\$	61.47	01323 (Bayer Hardware & Supply)	2022002863	WW_masonry supplies
		12/9/2022	6021214	\$	3,900.00	00144 (Kalida Truck Equipment, Inc.)	2022002782	WW_hydraulic plow for Kawasaki
		12/31/2022	CC:65351	\$	95.90	07600 (Fifth Third Credit Card)	2022003245	WW_Graem's Nov 2022 cc ref: 2022000133
100.6007.531100	OFFICE SUPPLIES - WW	12/31/2022	CC:65351	\$	213.26	07600 (Fifth Third Credit Card)	2022003245	WW_Graem's Nov 2022 cc ref: 2022000133
100.6007.531800	CLEANING SUPPLIES - WW	12/9/2022	6021207	\$	455.65	06733 (Fastenal Company)	2022002115	WW_Fastenal vending

		12/9/2022	6021207	\$	210.98	06733 (Fastenal Company)	2022002115	WW_Fastenal vending
		12/23/2022	6021308	\$	1,265.90	06733 (Fastenal Company)	2022002115	WW_Fastenal vending
100.6007.533500	Ops. M&S-Structures	12/16/2022	9892	\$	407.32	04571 (Lowe's)	2022003231	DW_Lowe's Dec 2022 paym ref: 2022000143
		12/9/2022	6021191	\$	118.92	01423 (21st Century Paints)	2022000159	WW_Paint and paint supplies
		12/31/2022	CC:65351	\$	1,753.69	07600 (Fifth Third Credit Card)	2022003245	WW_Graem's Nov 2022 cc ref: 2022000133
100.6007.533600	Ops. M&S-Grounds	12/16/2022	9892	\$	128.03	04571 (Lowe's)	2022003231	DW_Lowe's Dec 2022 paym ref: 2022000143
		12/9/2022	67349	\$	308.19	08048 (Oaks Feed Company, LLC)	2022000171	WW_WOW bird seed
		12/2/2022	6021161	\$	383.16	01864 (Century Equipment)	2022002859	WW_mower parts
		12/31/2022	CC:65351	\$	215.08	07600 (Fifth Third Credit Card)	2022003245	WW_Graem's Nov 2022 cc ref: 2022000133
100.6007.533700	Ops. M&S-Equip.	12/16/2022	9892	\$	21.31	04571 (Lowe's)	2022003231	DW_Lowe's Dec 2022 paym ref: 2022000143
		12/31/2022	CC:65351	\$	493.36	07600 (Fifth Third Credit Card)	2022003245	WW_Graem's Nov 2022 cc ref: 2022000133
100.6007.533800	Ops. M&S-Paper Products	12/31/2022	CC:65351	\$	45.69	07600 (Fifth Third Credit Card)	2022003245	WW_Graem's Nov 2022 cc ref: 2022000133
100.6007.533900	Ops. M&S-Cleaning Supplies	12/16/2022	9892	\$	384.82	04571 (Lowe's)	2022003231	DW_Lowe's Dec 2022 paym ref: 2022000143
		12/31/2022	CC:65351	\$	168.63	07600 (Fifth Third Credit Card)	2022003245	WW_Graem's Nov 2022 cc ref: 2022000133
100.6007.540200	SEPTIC - WW	12/23/2022	6021327	\$	300.00	00370 (Randy Mastin Septic Tank, Inc.)	2022000093	WW_Septic
100.6007.540300	WATER - WW	12/9/2022	9877	\$	6.00	02063 (Department of Public Utilities)	2022000050	WW_Water usage
		12/9/2022	9877	\$	216.14	02063 (Department of Public Utilities)	2022000050	WW_Water usage
		12/9/2022	9877	\$	776.87	02063 (Department of Public Utilities)	2022000050	WW_Water usage
		12/16/2022	9883	\$	244.65	02063 (Department of Public Utilities)	2022000050	WW_Water usage
		12/30/2022	9911	\$	68.28	02063 (Department of Public Utilities)	2022000050	WW_Water usage
100.6007.540400	ELECTRIC - WW	12/9/2022	9881	\$	67.15	01320 (Toledo Edison)	2022000135	WW_Electric usage
		12/23/2022	9904	\$	4,896.99	01320 (Toledo Edison)	2022000135	WW_Electric usage
100.6007.540500	GAS/ DIESEL - WW	12/23/2022	6021301	\$	511.71	08250 (Crystal Flash)	2022000073	WW_Gasoline and diesel for off road
		12/23/2022	6021301	\$	402.42	08250 (Crystal Flash)	2022000073	WW_Gasoline and diesel for off road
100.6007.540600	HEATING FUEL - WW	12/30/2022	9909	\$	893.91	01924 (Columbia Gas)	2022000141	WW_Gas usage
		12/30/2022	9909	\$	227.72	01924 (Columbia Gas)	2022000141	WW_Gas usage
		12/30/2022	9909	\$	395.92	01924 (Columbia Gas)	2023000018	WW_KS_Gas usage
		12/30/2022	9909	\$	722.22	01924 (Columbia Gas)	2023000018	WW_KS_Gas usage
		12/30/2022	9909	\$	2,067.27	01924 (Columbia Gas)	2023000018	WW_KS_Gas usage
		12/30/2022	9909	\$	287.52	01924 (Columbia Gas)	2023000018	WW_KS_Gas usage
		12/30/2022	9909	\$	1,517.71	01924 (Columbia Gas)	2023000018	WW_KS_Gas usage
100.6007.551900	MISC CONTRACT SVCS - WW	12/2/2022	67318	\$	220.00	5188 (CD Building Services, LLC)	2022002046	WW_Farmhouse Floor Waxing
		12/9/2022	6021202	\$	102.40	03899 (Culligan of Northwest Ohio)	2022002515	WW_water delivery
		12/9/2022	6021202	\$	40.45	03899 (Culligan of Northwest Ohio)	2022002515	WW_water delivery
		12/16/2022	6021275	\$	1,190.00	07749 (Scott Electric LLC)	2022003065	WW_Bluff Lighting Repair
		12/23/2022	6021328	\$	68.00	08435 (Rose Pest Solutions)	2022002314	WW_pest control services
		12/23/2022	6021328	\$	67.00	08435 (Rose Pest Solutions)	2022002314	WW_pest control services
		12/23/2022	6021328	\$	55.00	08435 (Rose Pest Solutions)	2022002314	WW_pest control services
		12/23/2022	6021328	\$	77.00	08435 (Rose Pest Solutions)	2022002314	WW_pest control services
		12/23/2022	6021328	\$	63.00	08435 (Rose Pest Solutions)	2022002314	WW_pest control services
		12/23/2022	6021328	\$	73.00	08435 (Rose Pest Solutions)	2022002314	WW_pest control services
100.6007.552700	OTHER EQUIPMENT REPAIR - WW	12/2/2022	6021163	\$	312.00	4631 (Coleman Systems, Inc.)	2022002902	WW_MPH service
		12/2/2022	6021185	\$	408.39	06416 (TK Elevator Corp.)	2022002912	WW_MH elevator tune up
100.6007.558300	Facility Systems Services	12/2/2022	6021163	\$	592.00	4631 (Coleman Systems, Inc.)	2022001470	WW_Preventative maintenance
		12/9/2022	6021199	\$	3,600.00	4631 (Coleman Systems, Inc.)	2022003002	WW_HVAC PMS
		12/23/2022	6021299	\$	839.00	4631 (Coleman Systems, Inc.)	2022003102	WW_HVAC repairs
100.6007.558500	Rolling Stock Repair	12/9/2022	6021203	\$	370.51	02999 (Crosby Equipment, LLC)	2022000023	WW_Repair parts and service for rolling stock
100.6007.558600	Fixed Equip. Repair	12/9/2022	6021230	\$	4,116.00	06416 (TK Elevator Corp.)	2022003007	WW_MH elevator repairs
100.6008.530900	OTHER OP MTRLS & SUPPLIES - BC	12/2/2022	67320	\$	12.88	02326 (General Pro Hardware)	2022001657	BC_Materials and Supplies
		12/2/2022	67320	\$	15.94	02326 (General Pro Hardware)	2022001657	BC_Materials and Supplies
		12/16/2022	67360	\$	4.60	02326 (General Pro Hardware)	2022001657	BC_Materials and Supplies
		12/16/2022	67360	\$	12.48	02326 (General Pro Hardware)	2022001657	BC_Materials and Supplies
		12/23/2022	67378	\$	6.99	02326 (General Pro Hardware)	2022001657	BC_Materials and Supplies
		12/31/2022	CC:65351	\$	140.26	07600 (Fifth Third Credit Card)	2022003255	OPBC_Brian's Nov 2022 cc ref: 2022000133
100.6008.540400	ELECTRIC - BC	12/30/2022	9915	\$	125.66	01320 (Toledo Edison)	2022000057	BC_Electric usage
		12/30/2022	9915	\$	1,348.59	01320 (Toledo Edison)	2022000057	BC_Electric usage
100.6008.540600	HEATING FUEL - BC	12/2/2022	6021175	\$	1,377.84	07381 (Ludwig Propane)	2022000117	BC_Propane usage
		12/2/2022	6021175	\$	9.36	07381 (Ludwig Propane)	2022000117	BC_Propane usage
		12/16/2022	6021264	\$	21.35	07381 (Ludwig Propane)	2022000117	BC_Propane usage

		12/23/2022	6021318	\$	445.28	07381 (Ludwig Propane)	2022000117	BC_Propane usage
100.6008.551900	MISC CONTRACT SVCS - BC	12/16/2022	6021256	\$	130.00	05234 (Co-Man)	2022002813	BC_Portable Toilet Rental
		12/16/2022	6021256	\$	215.00	05234 (Co-Man)	2022002813	BC_Portable Toilet Rental
100.6008.558200	GROUNDS M&R - BC	12/31/2022	CC:65351	\$	14.00	07600 (Fifth Third Credit Card)	2022003255	OPBC_Brian's Nov 2022 cc ref: 2022000133
100.6009.530101	Sm Equip/Furn/Fixtures_GC	12/31/2022	CC:65351	\$	488.00	07600 (Fifth Third Credit Card)	2022003244	GC_Lorenzo's Nov 2022 cc ref: 2022000133
100.6009.530900	OTHER OP MTRLS & SUPPLIES - MIG	12/16/2022	9892	\$	133.72	04571 (Lowe's)	2022003231	DW_Lowe's Dec 2022 paym ref: 2022000143
100.6009.530901	OTHER OP MTRLS & SUPPLIES - GC	12/16/2022	67362	\$	352.00	5384 (Harrell's Inc.)	2022003075	GC_Grass seed
		12/2/2022	6021170	\$	22.20	02374 (Grainger)	2022002918	GC_PPE
		12/31/2022	CC:65351	\$	874.37	07600 (Fifth Third Credit Card)	2022003244	GC_Lorenzo's Nov 2022 cc ref: 2022000133
100.6009.531800	CLEANING SUPPLIES - MIG	12/23/2022	6021308	\$	207.01	06733 (Fastenal Company)	2022002357	MM_monthly cleaning supplies
100.6009.531801	Cleaning Supplies - GC	12/31/2022	CC:65351	\$	109.29	07600 (Fifth Third Credit Card)	2022003244	GC_Lorenzo's Nov 2022 cc ref: 2022000133
100.6009.531802	CLEANING SUPPLIES - MM	12/9/2022	6021211	\$	38.88	02374 (Grainger)	2022003038	MM__cleaning supplies
		12/9/2022	6021211	\$	23.64	02374 (Grainger)	2022003038	MM__cleaning supplies
		12/9/2022	6021211	\$	17.40	02374 (Grainger)	2022003038	MM__cleaning supplies
		12/9/2022	6021211	\$	115.12	02374 (Grainger)	2022003038	MM__cleaning supplies
		12/9/2022	6021211	\$	20.64	02374 (Grainger)	2022003038	MM__cleaning supplies
		12/23/2022	6021312	\$	112.75	02374 (Grainger)	2022003038	MM__cleaning supplies
100.6009.533501	Ops. M&S-Structures- GC	12/31/2022	CC:65351	\$	189.99	07600 (Fifth Third Credit Card)	2022003244	GC_Lorenzo's Nov 2022 cc ref: 2022000133
100.6009.533601	Ops. M&S-Grounds- GC	12/31/2022	CC:65351	\$	238.59	07600 (Fifth Third Credit Card)	2022003244	GC_Lorenzo's Nov 2022 cc ref: 2022000133
100.6009.540300	WATER - MIG	12/23/2022	9902	\$	442.23	02063 (Department of Public Utilities)	2022000067	MIG_Water usage
100.6009.540301	WATER - GC	12/9/2022	67343	\$	939.50	02063 (Department of Public Utilities)	2022000059	GC_Water usage
100.6009.540401	ELECTRIC - GC	12/16/2022	9884	\$	172.19	01320 (Toledo Edison)	2022000138	GC_Electric uage
		12/16/2022	9884	\$	83.40	01320 (Toledo Edison)	2022000138	GC_Electric uage
		12/16/2022	9884	\$	1,801.72	01320 (Toledo Edison)	2022000138	GC_Electric uage
		12/23/2022	9904	\$	347.27	01320 (Toledo Edison)	2022000138	GC_Electric uage
		12/9/2022	67356	\$	318.39	01320 (Toledo Edison)	2022000138	GC_Electric uage
		12/23/2022	67388	\$	564.61	01320 (Toledo Edison)	2022000138	GC_Electric uage
100.6009.540402	ELECTRIC - MM	12/9/2022	9881	\$	184.04	01320 (Toledo Edison)	2022000091	MM_Electric usage
100.6009.551900	MISC CONTRACT SVCS - MIG	12/2/2022	6021186	\$	923.00	4810 (TruGreen & Action Pest Control)	2022002838	MG_turf aeration
100.6009.551901	MISC CONTRACT SVCS - GC	12/9/2022	67353	\$	11,850.00	5694 (Rink Management Services)	2022002725	GC_Operation of the skating concession
		12/16/2022	67364	\$	11,850.00	5694 (Rink Management Services)	2022002725	GC_Operation of the skating concession
		12/16/2022	67364	\$	50,000.00	5694 (Rink Management Services)	2022003048	GC_rink operating costs
		12/2/2022	6021165	\$	443.00	5483 (Fish Window Cleaning)	2022000871	GC_window cleaning
		12/2/2022	6021165	\$	48.00	5483 (Fish Window Cleaning)	2022002756	GC_pavilion window cleaning
		12/2/2022	6021166	\$	300.00	08558 (Foreman Irrigation Supply, Inc.)	2022002857	GC_Downtown irrigation winterization
		12/2/2022	6021166	\$	362.00	08558 (Foreman Irrigation Supply, Inc.)	2022002857	GC_Downtown irrigation winterization
		12/2/2022	6021180	\$	2,992.30	5686 (Ranker Lawn/Outdoor Obsessions)	2022002550	GC_Hydroseed along parkway
		12/2/2022	6021180	\$	2,808.10	5686 (Ranker Lawn/Outdoor Obsessions)	2022002778	GC_ravine soil work
		12/9/2022	6021209	\$	315.00	5483 (Fish Window Cleaning)	2022002756	GC_pavilion window cleaning
100.6009.552501	TREE WORK - GC	12/9/2022	6021193	\$	23.50	00246 (A.M. Leonard, Inc.)	2022003041	GC_Tree Treatments
		12/23/2022	6021293	\$	1,349.96	00246 (A.M. Leonard, Inc.)	2022003041	GC_Tree Treatments
100.6009.558301	FACILITY SYSTEMS SERVICES -GC	12/23/2022	6021316	\$	2,442.43	5563 (Johnson Controls Inc.)	2022003010	GC_emergency hvac repairs
100.6009.558400	Fleet Veh. Repair GC	12/31/2022	CC:65351	\$	238.96	07600 (Fifth Third Credit Card)	2022003244	GC_Lorenzo's Nov 2022 cc ref: 2022000133
100.6010.530100	SM EQUIP/ FURN/ FIXTURES - TBG	12/23/2022	67372	\$	639.98	5514 (Ag-Pro Ohio, LLC)	2022002657	TBG_Backpack blower
100.6010.530900	OTHER OP MTRLS & SUPPLIES - TBG	12/16/2022	9892	\$	402.81	04571 (Lowe's)	2022003231	DW_Lowe's Dec 2022 paym ref: 2022000143
		12/23/2022	6021330	\$	140.00	00987 (Sandman Sales Yard, LLC)	2022003095	TBG_topsoil
		12/31/2022	CC:65351	\$	93.58	07600 (Fifth Third Credit Card)	2022003271	TBG_Steve's Nov 2022 cc ref: 2022000133
100.6010.540300	WATER - TBG	12/9/2022	9877	\$	700.11	02063 (Department of Public Utilities)	2022000055	TBG_Water usage
		12/16/2022	9883	\$	546.29	02063 (Department of Public Utilities)	2022000055	TBG_Water usage
100.6010.540400	ELECTRIC - TBG	12/9/2022	9881	\$	222.77	01320 (Toledo Edison)	2022000048	TBG_Electric usage
		12/9/2022	9881	\$	151.50	01320 (Toledo Edison)	2022000048	TBG_Electric usage
		12/9/2022	9881	\$	262.55	01320 (Toledo Edison)	2022000048	TBG_Electric usage
		12/9/2022	9881	\$	67.80	01320 (Toledo Edison)	2022000048	TBG_Electric usage
		12/16/2022	9884	\$	661.17	01320 (Toledo Edison)	2022000048	TBG_Electric usage

		12/16/2022	9884	\$	153.51	01320 (Toledo Edison)	2022000048	TBG_Electric usage
		12/16/2022	9884	\$	98.74	01320 (Toledo Edison)	2022000048	TBG_Electric usage
		12/23/2022	9904	\$	147.19	01320 (Toledo Edison)	2022000048	TBG_Electric usage
100.6010.540600	HEATING FUEL - TBG	12/30/2022	9909	\$	669.16	01924 (Columbia Gas)	2022000049	TBG_Gas usage
		12/30/2022	9909	\$	44.56	01924 (Columbia Gas)	2022000049	TBG_Gas usage
		12/30/2022	9909	\$	284.73	01924 (Columbia Gas)	2022000049	TBG_Gas usage
		12/30/2022	9909	\$	2,549.42	01924 (Columbia Gas)	2022000049	TBG_Gas usage
		12/30/2022	9909	\$	214.44	01924 (Columbia Gas)	2023000029	TBG_KS_Gas usage
100.6010.551900	MISC CONTRACT SVCS - TBG	12/28/2022	67390	\$	(550.00)	4631 (Coleman Systems, Inc.)	2022001450	TBG_Preventative maintenance
		12/28/2022	67390	\$	(1,350.00)	4631 (Coleman Systems, Inc.)	2022001450	TBG_Preventative maintenance
		12/9/2022	6021228	\$	1,400.00	4711 (Superior Irrigation Ltd.)	2022002557	TBG_Irrigation winterization
		12/23/2022	6021310	\$	1,828.58	4924 (Frogtown Roofing, LLC)	2022002102	TBG_Conference Center roof repairs
100.6010.555100	EQUIPMENT RENTAL - TBG	12/9/2022	67345	\$	1,065.00	07149 (Great Lakes Rental LLC)	2022002553	TBG_lift rental
100.6010.558300	Facility Systems Services	12/28/2022	67390	\$	550.00	4631 (Coleman Systems, Inc.)	2022001450	TBG_Preventative maintenance
		12/28/2022	67390	\$	1,350.00	4631 (Coleman Systems, Inc.)	2022001450	TBG_Preventative maintenance
100.6010.558500	ROLLING STOCK REPAIR - TBG	12/31/2022	CC:65351	\$	134.46	07600 (Fifth Third Credit Card)	2022003271	TBG_Steve's Nov 2022 cc ref: 2022000133
		12/31/2022	CC:65356	\$	129.50	01285 (Tireman Auto Service Centers)	2022002743	TBG_tractor tire
100.6010.580500	OTHER EXP BUDGET MGMT - TBG	12/31/2022	CC:65351	\$	320.00	07600 (Fifth Third Credit Card)	2022003264	PRG_Shannon's Nov 2022 cc ref: 2022000133
100.6101.530900	OTHER OP MTRLS & SUPPLIES à€" EAST	12/16/2022	67358	\$	3,550.00	5683 (Ag-Pro-Berkey, OH LLC)	2022002381	NRE_John Deere MX& Lift-Type Rotary Cutter
100.6101.551900	MISC CONTRACT SVCS à€" EAST	12/16/2022	6021280	\$	1,991.00	01328 (Toledo Fence & Supply Co.)	2022002728	HM_Phase 2 service entrance gate
100.6103.530900	OTHER OP MTRLS & SUPPLIES à€" CENTRAL	12/23/2022	6021307	\$	5,216.00	01597 (DWA Recreation, Inc.)	2022002832	OPS_WW_East Side Drinking Fountain
		12/31/2022	CC:65351	\$	125.02	07600 (Fifth Third Credit Card)	2022003229	OPS_Lisa's Nov 2022 cc ref: 2022000133
100.6103.551900	MISC CONTRACT SVCS - CENTRAL	12/2/2022	6021168	\$	1,342.60	4924 (Frogtown Roofing, LLC)	2022002785	OPS_WW_Farmhouse Roof Repair
100.7000.520800	MILEAGE - NR	12/2/2022	6021155	\$	53.13	5223 (Jonathan Walasinski)	2022000229	NR_2022 mileage
		12/9/2022	6021247	\$	146.19	05023 (Tim Schetter)	2022000229	NR_2022 mileage
		12/9/2022	6021250	\$	81.56	5697 (Zurijanne Carter)	2022000229	NR_2022 mileage
		12/16/2022	6021288	\$	161.25	5593 (Jay Wright)	2022000229	NR_2022 mileage
		12/31/2022	CC:65351	\$	2.00	07600 (Fifth Third Credit Card)	2022000229	NR_2022 mileage
100.7000.550100	CONFERENCES/ TRAINING - NR	12/2/2022	67323	\$	95.00	06243 (Ohio Department of Commerce)	2022002919	NR_fire training for Emily Main
		12/31/2022	CC:65351	\$	35.00	07600 (Fifth Third Credit Card)	2022003248	NRW_LaRae's Nov 2022 cc ref: 2022000133
100.7000.550200	MEMBERSHIP DUES - NR	12/31/2022	CC:65351	\$	346.00	07600 (Fifth Third Credit Card)	2022003266	NR_Tim S' Nov 2022 cc ref: 2022000133
100.7000.552600	NATURAL AREA RESEARCH - NR	12/9/2022	67348	\$	900.00	5703 (John Wiley and Sons Inc.)	2022002806	NR_page charges for WSB publication
		12/2/2022	6021174	\$	766.67	5585 (Madisyn Rex)	2022001595	NR_assistance with dredge research project at Glass City
100.7000.557100	UNIFORMS - NR	12/2/2022	6021183	\$	139.99	01227 (Superior Uniform Sales, Inc.)	2022000407	NR_Nick Weitzel's 2022 uniform allowance
		12/2/2022	6021183	\$	362.50	01227 (Superior Uniform Sales, Inc.)	2022000412	NatRes_Penny Niday's 2022 uniform allowance
		12/9/2022	6021195	\$	325.92	08615 (AIA Corporation)	2022001578	NR_Jay Write logo wear
		12/9/2022	6021221	\$	90.49	5653 (PGN Consulting)	2022000405	NR_Tim Gallaher's 2022 uniform allowance
		12/16/2022	6021254	\$	31.41	08615 (AIA Corporation)	2022000435	NR_Julie Weidner's 2022 uniform allowance
		12/16/2022	6021254	\$	856.78	08615 (AIA Corporation)	2022000770	NR_Seasonal Tshirts and hats
		12/16/2022	6021269	\$	28.02	5653 (PGN Consulting)	2022000407	NR_Nick Weitzel's 2022 uniform allowance
		12/16/2022	6021277	\$	232.25	01227 (Superior Uniform Sales, Inc.)	2022000404	NR_LaRae Sprow's 2022 uniform allowance
100.7001.530900	OTHER OP MTRLS & SUPPLIES - NRW	12/31/2022	CC:65351	\$	628.31	07600 (Fifth Third Credit Card)	2022003248	NRW_LaRae's Nov 2022 cc ref: 2022000133
100.7001.551900	MISC CONTRACT SVCS - NRW	12/2/2022	67337	\$	94.00	5679 (Purdue University)	2022002820	NRW_oak wilt sampling diagnostic lab
		12/2/2022	67337	\$	66.00	5679 (Purdue University)	2022002820	NRW_oak wilt sampling diagnostic lab
100.7001.552700	OTHER EQUIPMENT REPAIR - NRW	12/2/2022	6021173	\$	535.00	5695 (J & G Auto Electric)	2022002875	NRW_Starter for chipper
		12/9/2022	6021192	\$	699.82	01706 (A.J. Boellner, Inc.)	2022001101	NRW_Flail repair
		12/31/2022	CC:65351	\$	716.10	07600 (Fifth Third Credit Card)	2022003248	NRW_LaRae's Nov 2022 cc ref: 2022000133
100.7001.555100	EQUIPMENT RENTAL - NRW	12/16/2022	6021276	\$	1,655.78	5288 (Skyworks, LLC)	2022002705	NRW_80 ft lift rental Oak Wilt
100.7003.530900	OTHER OP MTRLS & SUPPLIES - BCN	12/2/2022	67339	\$	59.51	01524 (Waldo & Associates, Inc.)	2022002915	Planting supplies
		12/31/2022	CC:65351	\$	1,575.19	07600 (Fifth Third Credit Card)	2022003257	BCN_Kerri's Nov 2022 cc ref: 2022000133
100.7003.531100	OFFICE SUPPLIES - BCN	12/16/2022	6021259	\$	170.54	02188 (Express Office Products Corp.)	2022003028	Office supplies
100.7004.530100	SM EQUIP/ FURN/ FIXTURES - NRE	12/16/2022	67358	\$	3,550.00	5683 (Ag-Pro-Berkey, OH LLC)	2022002381	NRE_John Deere MX& Lift-Type Rotary Cutter
		12/31/2022	CC:65351	\$	527.50	07600 (Fifth Third Credit Card)	2022003238	NRE_Denis's Nov 2022 cc ref: 2022000133
		12/31/2022	CC:65351	\$	150.00	07600 (Fifth Third Credit Card)	2022003269	NRE_Sam's Nov 2022 cc ref: 2022000133

100.7004.530900	OTHER OP MTRLS & SUPPLIES - NRE	12/2/2022	67336	\$	150.00	5283 (Plymale Farms)	2022000981	NRE_Straw bales/seeding @ GC
		12/2/2022	67336	\$	105.00	5283 (Plymale Farms)	2022002638	NRE_Straw bales/seeding @ GC
		12/31/2022	CC:65351	\$	1,517.06	07600 (Fifth Third Credit Card)	2022003237	NRE_Kaylah's Nov 2022 cc ref: 2022000133
		12/31/2022	CC:65351	\$	311.10	07600 (Fifth Third Credit Card)	2022003238	NRE_Denis's Nov 2022 cc ref: 2022000133
		12/31/2022	CC:65351	\$	2,983.16	07600 (Fifth Third Credit Card)	2022003269	NRE_Sam's Nov 2022 cc ref: 2022000133
100.7004.540400	ELECTRIC - NRE	12/23/2022	9904	\$	73.43	01320 (Toledo Edison)	2022000061	HM_Electric usage (approved by Denis Franklin)
		12/30/2022	9915	\$	529.49	01320 (Toledo Edison)	2022000061	HM_Electric usage (approved by Denis Franklin)
		12/30/2022	9915	\$	73.00	01320 (Toledo Edison)	2022000061	HM_Electric usage (approved by Denis Franklin)
100.7004.551900	MISC CONTRACT SVCS - NRE	12/16/2022	6021254	\$	89.76	08615 (AIA Corporation)	2022001668	T shirts for FT staff
		12/16/2022	6021280	\$	2,000.00	01328 (Toledo Fence & Supply Co.)	2022002728	HM_Phase 2 service entrance gate
100.7004.552700	OTHER EQUIPMENT REPAIR - NRE	12/31/2022	CC:65351	\$	620.81	07600 (Fifth Third Credit Card)	2022003237	NRE_Kaylah's Nov 2022 cc ref: 2022000133
		12/31/2022	CC:65351	\$	224.54	07600 (Fifth Third Credit Card)	2022003269	NRE_Sam's Nov 2022 cc ref: 2022000133
100.7005.530100	SM EQUIP/ FURN/ FIXTURES - NRC	12/2/2022	6021181	\$	2,261.08	07054 (Sprayer Depot)	2022002894	NRC_HERB Replacment motor and pump for Reers unit
100.7005.530900	OTHER OP MTRLS & SUPPLIES - NRC	12/31/2022	CC:65351	\$	256.60	07600 (Fifth Third Credit Card)	2022003267	NRC_Tim G's Nov 2022 cc ref: 2022000133
100.9000.520800	MILEAGE - PH	12/9/2022	6021246	\$	181.81	08314 (Staci Stasiak-Irons)	2022002055	PH_Mileage - PH Dept. Additional
		12/31/2022	CC:65351	\$	3.15	07600 (Fifth Third Credit Card)	2022003234	PH_Kate's Nov 2022 cc ref: 2022000133
100.9000.531100	OFFICE SUPPLIES - PH	12/31/2022	CC:65351	\$	16.99	07600 (Fifth Third Credit Card)	2022003250	PH_Jackie's Nov 2022 cc ref: 2022000133
100.9000.550100	CONFERENCES/ TRAINING - PH	12/31/2022	CC:65351	\$	290.00	07600 (Fifth Third Credit Card)	2022003250	PH_Jackie's Nov 2022 cc ref: 2022000133
		12/31/2022	CC:65351	\$	320.00	07600 (Fifth Third Credit Card)	2022003264	PRG_Shannon's Nov 2022 cc ref: 2022000133
100.9000.553600	Engagement Activities - PH	12/9/2022	6021222	\$	604.00	03932 (One Day Sign, Inc.)	2022002906	PH_Glass City Supporter On-Site Signs
100.9000.557100	UNIFORMS - PH	12/2/2022	6021160	\$	242.47	08615 (AIA Corporation)	2022001433	PH_Jackie Uniform Allowance
		12/2/2022	6021179	\$	127.52	5653 (PGN Consulting)	2022000347	PH_Uniform - Kate
		12/2/2022	6021179	\$	55.00	5653 (PGN Consulting)	2022001433	PH_Jackie Uniform Allowance
		12/9/2022	6021221	\$	100.99	5653 (PGN Consulting)	2021000345	PH_Effler Uniform Allowance
		12/9/2022	6021221	\$	57.00	5653 (PGN Consulting)	2022000347	PH_Uniform - Kate
201.0000.470000	DONATIONS - UNRESTRICTED	12/16/2022	6021285	\$	39,277.59	5130 (Metroparks Toledo Foundation)	2022002700	Reference Receipt 2022000000161
201.1000.580900	OTHER OPERATIONAL EXPENDITURES - OD	12/31/2022	CC:65351	\$	142.37	07600 (Fifth Third Credit Card)	2022003263	OD_Dave's Nov 2022 cc ref: 2022000133
		12/31/2022	CC:65351	\$	46.43	07600 (Fifth Third Credit Card)	2022003262	OD_Jill's Nov 2022 cc ref: 2022000133
201.3001.520700	MISC BENEFITS - ES	12/9/2022	6021221	\$	2,015.35	5653 (PGN Consulting)	2022002755	AD_Logo Wear
201.9000.580900	211505100 OTHER OPERATIONAL EXPENDITURES - PH	12/9/2022	6021205	\$	1,335.00	00835 (Digitimatics, Inc.)	2022002166	PH_Anderson Bridge Donor Plaque
		12/9/2022	6021205	\$	94.70	00835 (Digitimatics, Inc.)	2022002861	PH_Swinging Bench Plaque Oaks Evergreen Lake Kamca
		12/23/2022	6021303	\$	408.00	00835 (Digitimatics, Inc.)	2022002466	PH_Memorial Bench Plaques (Rafeeq, Conda)
202.5003.551900	20201003 MISC CONTRACT SERVICES - CR	12/9/2022	6021210	\$	71,170.00	08279 (Game Time, Inc.)	2022001695	OPS_PE_Poured-In-Place Rubber Playground Surfacing
202.6000.530900	20163802 OTHER OP MTRLS & SUPPLIES - OPS	12/2/2022	67322	\$	5,940.00	5374 (Keystone Ridge Designs, Inc.)	2022001094	TBG_Memorial Benches
202.7000.551900	MISC CONTRACT SVCS - NR	12/28/2022	67391	\$	2,700.00	5066 (Running Wild Media)	2022003273	NR_nursery video production
202.7000.580900	220504302 OTHER OPERATIONAL EXPENDITURES - NR	12/31/2022	CC:65351	\$	1,029.45	07600 (Fifth Third Credit Card)	2022003248	NRW_LaRae's Nov 2022 cc ref: 2022000133
202.8002.530900	223408102 OTHER OP MTRLS & SUPPLIES - Public Programs (formerly ODS)	12/31/2022	CC:65351	\$	875.25	07600 (Fifth Third Credit Card)	2022003235	MKTG_Trish's Nov 2022 cc ref: 2022000133
202.8002.551900	223408102 MISC CONTRACT SERVICES - Public Programs (formerly ODS)	12/9/2022	67347	\$	499.00	5562 (Imagination Station)	2022002908	PROG_SOW Oct. 18 Film Licensing
		12/31/2022	CC:65351	\$	(11.55)	07600 (Fifth Third Credit Card)	2022003243	PH_Staci's Nov 2022 cc ref: 2022000133
202.8003.530100	221607103 SM EQUIP/ FURN/ FIXTURES - PRG	12/23/2022	6021315	\$	2,995.00	5690 (GRIT)	2022002702	PRG_GRIT Freedom Chair: 3.0-20" Standard Drivetrain
	223408102	12/31/2022	CC:65351	\$	660.85	07600 (Fifth Third Credit Card)	2022003232	PRG_ODS_Ashley's Nov 2022 cc ref: 2022000133
202.8003.551900	MISC CONTRACT SVCS - PRG	12/31/2022	CC:65351	\$	212.85	07600 (Fifth Third Credit Card)	2022003264	PRG_Shannon's Nov 2022 cc ref: 2022000133
204.8002.520800	MILEAGE - PRG_ODS	12/9/2022	6021233	\$	50.63	4663 (Alissa Barwinski Caple)	2022001527	PRG_ODS_Mileage
		12/9/2022	6021236	\$	75.31	5457 (Caitlin Brandesky)	2022001527	PRG_ODS_Mileage
		12/9/2022	6021238	\$	31.88	5377 (Jessica Schaefer)	2022001527	PRG_ODS_Mileage
		12/9/2022	6021239	\$	41.88	5556 (Jesse Oestreich)	2022001527	PRG_ODS_Mileage
		12/16/2022	6021286	\$	54.38	08494 (Amanda Domalski)	2022001527	PRG_ODS_Mileage
204.8002.532100	ED ACTIVITY SUPPLIES - PRG_ODS	12/31/2022	CC:65351	\$	80.23	07600 (Fifth Third Credit Card)	2022003233	PRG_ODS_Morgan's Nov 2022 cc ref: 2022000133
		12/31/2022	CC:65351	\$	33.23	07600 (Fifth Third Credit Card)	2022003232	PRG_ODS_Ashley's Nov 2022 cc ref: 2022000133
204.8002.550100	CONFERENCES/ TRAINING - PRG_ODS	12/31/2022	CC:65351	\$	375.00	07600 (Fifth Third Credit Card)	2022002289	PRG_ODS_Jake WFR Recert
		12/31/2022	CC:65351	\$	22.04	07600 (Fifth Third Credit Card)	2022003232	PRG_ODS_Ashley's Nov 2022 cc ref: 2022000133

204.8002.551900	MISC CONTRACT SVCS - PRG_ODS	12/9/2022	6021194	\$	2,340.00	4705 (Adventure Tree LLC)	2022002022	PRG_ODS_Tree inspections
204.8002.557100	UNIFORMS - PRG_ODS	12/9/2022	6021195	\$	169.00	08615 (AIA Corporation)	2022003081	PRG_ODS_Ashley uniform purchase
		12/9/2022	6021221	\$	19.99	5653 (PGN Consulting)	2022002064	PRG_ODS_Alissa Caple Uniform Allowance
		12/9/2022	6021221	\$	19.99	5653 (PGN Consulting)	2022002068	PRG_ODS_Jessica Schaefer Uniform Allowance
		12/31/2022	CC:65351	\$	114.49	07600 (Fifth Third Credit Card)	2022002064	PRG_ODS_Alissa Caple Uniform Allowance
		12/31/2022	CC:65351	\$	230.91	07600 (Fifth Third Credit Card)	2022002065	PRG_ODS_Amanda Domalski Uniform Allowance
204.8002.580900	OTHER OPERATIONAL EXPENDITURES - PRG_ODS	12/23/2022	6021338	\$	12.25	02555 (Toledo Water Conditioning)	2022000962	PRG_ODS_Water Refills
		12/31/2022	CC:65351	\$	11.94	07600 (Fifth Third Credit Card)	2022003232	PRG_ODS_Ashley's Nov 2022 cc ref: 2022000133
		12/31/2022	CC:65351	\$	63.66	07600 (Fifth Third Credit Card)	2022003259	PRG_ODS_Jessica's Nov 2022 cc ref: 2022000133
		12/31/2022	CC:65351	\$	14.62	07600 (Fifth Third Credit Card)	2022003233	PRG_ODS_Morgan's Nov 2022 cc ref: 2022000133
204.8003.520300	Health Insurance - PRG_EE	12/9/2022	6021216	\$	13,930.77	02544 (Lucas County Treasurer)	2022000132	Health Insurance Prg
		12/9/2022	6021216	\$	1,829.71	02544 (Lucas County Treasurer)	2022000132	Health Insurance Prg
204.8003.520800	MILEAGE - PRG_EE	12/9/2022	6021237	\$	107.25	5590 (Jason George)	2022001820	PRG_Mileage-Programming
		12/9/2022	6021241	\$	227.31	5558 (Jonah Beale)	2022001820	PRG_Mileage-Programming
		12/9/2022	6021242	\$	100.50	4869 (Madison Lindsay)	2022001820	PRG_Mileage-Programming
		12/9/2022	6021243	\$	31.88	5662 (Meg Clark)	2022001820	PRG_Mileage-Programming
		12/9/2022	6021244	\$	171.88	02484 (Kimberly High)	2022001820	PRG_Mileage-Programming
		12/9/2022	6021245	\$	279.38	5055 (Nick Dian)	2022001820	PRG_Mileage-Programming
		12/16/2022	6021287	\$	113.13	4893 (Devon Donnelly)	2022001820	PRG_Mileage-Programming
		12/16/2022	6021289	\$	38.13	06534 (Jennifer Elsworth)	2022001820	PRG_Mileage-Programming
204.8003.531100	OFFICE SUPPLIES - PRG_EE	12/31/2022	CC:65351	\$	111.76	07600 (Fifth Third Credit Card)	2022003264	PRG_Shannon's Nov 2022 cc ref: 2022000133
204.8003.532100	ED ACTIVITY SUPPLIES - PRG_EE	12/9/2022	67346	\$	435.00	5376 (I Do Chair Covers, LTD)	2022003020	PRG_Rental Linens
		12/31/2022	CC:65351	\$	449.17	07600 (Fifth Third Credit Card)	2022003264	PRG_Shannon's Nov 2022 cc ref: 2022000133
204.8003.557100	UNIFORMS - PRG_EE	12/2/2022	6021179	\$	78.99	5653 (PGN Consulting)	2022002375	PRG_Nick Dian Uniform
		12/23/2022	6021294	\$	450.00	08615 (AIA Corporation)	2022000923	PRG_Uniforms
205.9001.580700	Membership Programs - MEM	12/23/2022	67380	\$	3,500.00	03392 (H.O.T. Graphic & Services, Inc.)	2022002645	MEM_2022 Year-End Book Printing
		12/23/2022	67380	\$	716.00	03392 (H.O.T. Graphic & Services, Inc.)	2022002874	MEM_2022 Year-End Book Printing Add'l Funds
		12/23/2022	6021326	\$	675.23	5653 (PGN Consulting)	2022003018	MEM_Good Natured Tote Bags
256.5001.551900	MISC CONTRACT SVCS - PC	12/23/2022	67385	\$	68,200.00	5440 (Spieker Company)	2021002690	PC_HM Amenities
256.7051.551900	20083500 MISC CONTRACT SVCS - Ohio EPA#319	12/23/2022	6021311	\$	33,629.78	02316 (Geddis Paving & Excavating, Inc.)	2022001294	PC_Restoration, Excavation & Construction of SE Wetland
256.7101.551900	20083500 MISC CONTRACT SVCS - NR	12/23/2022	6021311	\$	65,565.71	02316 (Geddis Paving & Excavating, Inc.)	2022001294	PC_Restoration, Excavation & Construction of SE Wetland
256.8032.533700	223407006 M&S Equip - Reeves Grant	12/31/2022	CC:65351	\$	7,834.65	07600 (Fifth Third Credit Card)	2022003259	PRG_ODS_Jessica's Nov 2022 cc ref: 2022000133
258.7121.551900	20083500 LOCAL GRANTS- MISC CONTRACT SVCS - Secor Expansion/Reforestation - Akron WRRSP	12/23/2022	6021311	\$	1,813.12	02316 (Geddis Paving & Excavating, Inc.)	2022001294	PC_Restoration, Excavation & Construction of SE Wetland
	20083500	12/23/2022	6021311	\$	2,745.67	02316 (Geddis Paving & Excavating, Inc.)	2022001294	PC_Restoration, Excavation & Construction of SE Wetland
258.8022.557100	22010001 UNIFORMS - My Mentor and Me	12/16/2022	6021254	\$	249.75	08615 (AIA Corporation)	2022001797	PRG_Uniforms for Mentor & Me
400.1201.572000	19061305 New Park	12/2/2022	6021187	\$	236,230.36	08459 (The Lathrop Company)	2020002511	PC_Glass City BID PACKAGE #2
400.5001.551900	20201013 MISC CONTRACT SVCS_Miscellaneous Planning	12/9/2022	67354	\$	1,031.25	04104 (T & J Excavating & Tree Clearing LLC)	2022003014	PC_UPT_Brush Removal Service for Surveying Needs
	20201013	12/2/2022	6021167	\$	18,050.00	4460 (Garcia Surveyors, Inc.)	2022001861	PC_UPT Extension Topographic Survey Services
	231809305	12/16/2022	6021281	\$	1,740.00	05725 (Total Environmental Services, LLC.)	2022003004	PC_TBG_Garden Cottage Pre-Demo Asbestos Abatement
		12/23/2022	6021296	\$	550.00	08773 (Bowser-Morner, Inc.)	2022000673	PC_SE Maintenance Shop Replacement - Testing
400.5001.572700	20212805 TRAIL INFRASTRUCTURE - PC	12/23/2022	6021313	\$	184,544.23	5416 (Great Lakes Demolition Co. LLC)	2021002173	PC_SW Connector Trail LUC PID 107469
400.5001.575100	20062605 MISC CAPITAL OUTLAY - PC	12/16/2022	6021265	\$	650,649.90	06681 (Mosser Construction. Inc.)	2021000726	PC_Riverside Trail & Bridge Construction
400.5003.571200	211505100 NEW STRUCTURES OTHER THAN BLDGS. - CR	12/23/2022	6021304	\$	44,459.67	07314 (Dotson Company, Inc.)	2021002820	PC_Brookwood Suspension Bridge
400.5003.573300	MACHINERY & EQUIPMENT - CR	12/9/2022	67341	\$	16,257.87	01864 (Century Equipment)	2022001872	DW_Club Car Carryall 700-WW
		12/23/2022	6021297	\$	11,550.00	03398 (Buck & Knobby Equipment)	2022003049	DW_Skid steer attachment-swing arm boom mower
401.7002.551200	APPRaiser/ SURVEYOR - LA	12/9/2022	6021215	\$	865.00	06594 (Lewandowski Engineers)	2022003017	LA_soil testing fee
404.2000.520300	Health Insurance - ES	12/9/2022	6021216	\$	2,447.82	02544 (Lucas County Treasurer)	2022002744	DW_Health Insurance
404.5001.551900	9905001500 MISC CONTRACT SVCS - PC	12/23/2022	6021331	\$	42,247.92	07761 (Smithgroup JIR, LLC)	2021001838	P&C_GC Phase Two Construction Services
404.5001.571000	9900051300 GC-PROF. SERV. (PLAN/ENG) EXP	12/2/2022	6021182	\$	53.70	5430 (Stanton Constructability Services, LLC)	2021002651	PC_Riverwalk Build - Independant Cost Estimating
	9900051300	12/2/2022	6021182	\$	554.60	5430 (Stanton Constructability Services, LLC)	2021002651	PC_Riverwalk Build - Independant Cost Estimating
	9900051300	12/23/2022	6021295	\$	274,206.00	5432 (Bergmann Associates)	2022001344	PC_Riverwalk Build Engineering 90% Design
	9900051300	12/23/2022	6021295	\$	236,551.91	5432 (Bergmann Associates)	2022001344	PC_Riverwalk Build Engineering 90% Design

404.5001.572000	9905000300	NEW PARK - GC RIVERWALK	12/2/2022	67321	\$	38,250.00	07881 (GRAPHITE DESIGN + BUILD LIMITED)	2022001928	PC_GC Custom Art Features
			12/2/2022	67338	\$	46,010.86	5632 (River City Furniture LLC)	2022001927	PC_GC_Phase Two Furnishing Procurement Services
			12/2/2022	6021184	\$	14,800.00	01234 (Swanton Welding & Machine Co., Inc.)	2022001606	PC_GC Owner Amenities: Kayak Locker Unit
			12/9/2022	6021220	\$	930.80	07089 (Nissen Concrete)	2022002848	PC_GC_Concrete for Playground Footer Install
			12/16/2022	6021278	\$	10,000.00	08459 (The Lathrop Company)	2022002160	PC_GC_Phase 2 CMAR Services - Construction, Sitework, ect.
			12/23/2022	6021306	\$	19,560.00	5421 (Duncan & Grove USA Ltd.)	2022003159	PC_GC_Prairie Pollinator Additional Freight Charge
			12/23/2022	6021323	\$	1,082.60	07089 (Nissen Concrete)	2022003067	PC_GC_Concrete for Playground Footers
			12/31/2022	CC:65351	\$	8,223.23	07600 (Fifth Third Credit Card)	2022003252	CC_Brad H's Nov 2022 cc ref: 2022000133
404.5001.575100	20062605	MISC CAP. IMPROVEMENTS - PC	12/16/2022	6021265	\$	86,117.75	06681 (Mosser Construction. Inc.)	2021000726	PC_Riverside Trail & Bridge Construction
404.5122.572000	9905000100	NEW PARK - GC RIVERWALK	12/16/2022	6021278	\$	548,271.25	08459 (The Lathrop Company)	2022002160	PC_GC Phase 2 CMAR Services - Construction, Sitework, ect.
			12/16/2022	6021278	\$	1,214,056.63	08459 (The Lathrop Company)	2022002457	PC_GC Phase 2 CMAR Services - Construction, Sitework, ect.
			12/16/2022	6021278	\$	137,369.52	08459 (The Lathrop Company)	2022002855	PC_GC Enrichment Center CMAR Services - Construction, Sitework, ect.
			12/16/2022	6021278	\$	136,406.42	08459 (The Lathrop Company)	2022002855	PC_GC Enrichment Center CMAR Services - Construction, Sitework, ect.
			12/23/2022	6021335	\$	143,424.62	08459 (The Lathrop Company)	2022002855	PC_GC Enrichment Center CMAR Services - Construction, Sitework, ect.
404.9000.551900		MISC CONTRACT SVCS - PH	12/9/2022	67344	\$	50,000.00	07881 (GRAPHITE DESIGN + BUILD LIMITED)	2022002903	PH_Glass City Donor Recognition Wall Design and Construction
			Grand Total		\$	6,304,603.75			

METROPOLITAN PARK DISTRICT OF THE TOLEDO AREA

_____ offered and moved adoption of the following resolution:

RESOLUTION NO. 09-23

**CONTRACT APPROVAL, PEARSON METROPARK TENNIS COURT IMPROVEMENTS & PICKLEBALL
CONVERSION**

WHEREAS, sealed proposals for bidding on the Pearson Metropark Tennis Court Improvements & Pickleball Conversion, 761 S. Lallendorf Rd., Oregon, OH 43616 were received Friday, January 6, 2023 at 10:00 AM, AND,

WHEREAS, One (1) bid was received with Laser Striping and Sport Surfacing being the apparent lowest and best bidder at \$82,900.00, AND,

WHEREAS, the Scope of Work consists of resealing and striping of the existing tennis courts with reconfiguration to provide two tennis courts and four pickleball courts. General construction involves sport court surfacing, color sealing, striping, crack filling, net installations, new fencing and other associated work, AND,

WHEREAS, the total cost of construction contracting is anticipated to be \$91,190.00 which includes the construction contract (\$82,900.00) plus a ten percent (10%) construction contingency (\$8,290.00), NOW, THEREFORE,

BE IT RESOLVED, that the Board of Park Commissioners hereby approves a construction contract with Laser Striping and Sport Resurfacing for Pearson Metropark Tennis Court Improvements & Pickleball Conversion not-to-exceed \$91,190.00. (Contract amount + ten percent (10%) contingency).

_____ seconded the motion and upon _____ vote the resolution was declared duly adopted and recorded in the appendix to these minutes.

CERTIFICATION

I hereby certify the foregoing to be a true and correct copy of a resolution duly adopted at the regular board meeting of the Metropolitan Park District of the Toledo Area held on January 18, 2023.

David D. Zenk
Executive Director

Approved as to Form:

(Amy Natyshak)
Attorney for the Board
January 18, 2023